

# **GUIDELINES FOR SEISMIC RETROFIT OF EXISTING BUILDINGS**

## **CHAPTER 4 EARTHQUAKE HAZARD REDUCTION IN EXISTING WOOD-FRAME RESIDENTIAL BUILDINGS WITH SOFT, WEAK OR OPEN-FRONT WALLS**

***with Commentary by the  
Structural Engineers Association of California  
Existing Buildings Committee***

*This chapter is part of the 2000 Edition of the Guidelines for Seismic Retrofit of Existing Buildings (GSREB), published in 2001 by the International Conference of Building Officials (ICBO). It has been reprinted in its entirety as Appendix Chapter A4 in the 2003 International Existing Building Code (IEBC). For voluntary seismic retrofit, IEBC section 707.7 specifically allows the use of GSREB provisions in lieu of the normal requirements specified in section 407.1.1.1. This commentary is intended to explain Chapter 4's technical provisions and their intended use.*

*The GSREB Preface gives a brief history of the GSREB, parts of which were first published as appendices to the Uniform Code for Building Conservation (UCBC). Chapter 4 has its origins in documents developed for the City of Los Angeles (Los Angeles, 1999) and the City of Fremont, CA (Fremont) after the 1994 Northridge earthquake.*

*In this document, all commentary is shown in italic text. For convenience, this commentary uses the acronym SWOF to refer to buildings, wall lines, or structural conditions characterized by soft, weak, or open-front walls.*

### **SECTION 401 GENERAL**

**401.1 Purpose.** The purpose of this chapter is to promote public welfare and safety by reducing the risk of death or injury that may result from the effects of earthquakes on existing wood-frame, multiunit residential buildings. The ground motions of past earthquakes have caused the loss of human life, personal injury and property damage in these types of buildings. This chapter creates minimum standards to strengthen the more vulnerable portions of these structures. When fully followed, these minimum standards will improve the performance of these buildings but will not necessarily prevent all earthquake-related damage.

*The Chapter 4 provisions are intended to prevent concentrations of structural damage in the vulnerable first stories of typical SWOF buildings.*

*These retrofit provisions are not intended to provide structural performance equivalent to that provided by new construction built in accordance with the Building Code. Model building codes for new construction intend "to safeguard against major structural failures and loss of life" (ICBO, 1997) or, more generally, "to safeguard the public health, safety and general welfare" (ICC, 2002). Modern code-based designs can be expected to prevent structural collapse, limit structural and nonstructural falling hazards, and provide safe egress. In addition, due to inherent conservatism, code-based designs can also be expected to offer some measure of damage control or repairability.*

*To meet such a standard, an existing SWOF building would require comprehensive investigation, testing, and analysis, possibly followed by extensive structural and nonstructural retrofit. Instead, the GSREB Chapter 4 provisions aim to "reduce the risk" with significantly less design effort, construction cost, and tenant disruption. Risk Reduction does not take a comprehensive approach to Life Safety, does not aim to protect property or function, and is not equivalent to new construction under the Building Code. For many owners, tenants, and jurisdictions, this Risk Reduction approach represents an acceptable tradeoff.*

*Risk Reduction identifies and improves the structure's "more vulnerable portions," often leaving the rest of the building untouched. The SWOF condition itself is considered to be by far the most hazardous attribute of a SWOF building, and retrofit of the SWOF wall line can be expected to substantially reduce the likelihood of excessive drift*

## GUIDELINES FOR SEISMIC RETROFIT OF EXISTING BUILDINGS

*or collapse. Indeed, if the SWOF condition is the building's only serious structural deficiency, proper retrofit of the SWOF condition might achieve the benefits of a full Life Safety retrofit. (Other examples of Risk Reduction retrofit schemes include the strengthening and bolting of unbraced cripple walls in a wood-frame house without consideration of the upper stories, and the bracing of parapets in unreinforced masonry buildings without consideration of the remaining URM walls.)*

*As with any building or retrofit code, the Chapter 4 provisions are formulated for certain typical conditions, and the intended performance is expected to be achieved by the great majority of the buildings to which the provisions apply. The performance of any specific building, however, might be better or worse than that intended by the provisions.*

*Section 401.1 refers to past earthquakes. Multistory SWOF buildings have shown unacceptable performance, including collapse and consequent loss of life, in the 1971 San Fernando, 1978 Santa Barbara, 1989 Loma Prieta, and 1994 Northridge earthquakes. For more information on their past performance, see Harris et al. (1990), Hamburger (1994), Mendes (1995), and Holmes and Somers (1996). For more information on analysis and retrofit approaches, see Vukazich (1998), LADBS (1999), and Rutherford and Chekene (2000).*

**401.2 Scope.** The provisions of this chapter shall apply to all existing wood-frame buildings, or portions thereof, that are used as hotels, lodging houses, congregate residences or apartment houses where:

1. The ground floor portion of the wood-frame structure contains parking or other similar open floor space that causes soft, weak or open-front wall lines as defined in this chapter, and there exists one or more levels above, or
2. The walls of any story or basement of wood construction are laterally braced with nonconforming structural materials as defined in this chapter, a soft or weak wall line exists as defined in this chapter, and there exist two or more levels above.

This chapter is applicable to Seismic Hazard Zones where  $S_{DI}$  is 0.3g or higher, or in Seismic Zones 3 and 4 of the UBC.

*Section 401.2 describes the construction, occupancy, deficiencies, and seismic hazard levels for which Chapter 4 is intended. In general, the provisions in Chapter 4 were conceived to address deficiencies in a building type commonly known as a "tuckunder," so called because a ground floor parking area is tucked under the upper stories. In California, many tuckunders were built in the 1960s and 1970s. Structural characteristics of a typical wood-frame tuckunder of this era include:*

*Perimeter walls sheathed on the exterior face with stucco (sometimes over plywood) and on the interior face with gypsum wallboard (drywall). In some cases, let-in braces were used instead of plywood, especially at upper stories.*

*Interior partitions sheathed with drywall on both sides.*

*No hold-down hardware.*

*Floors of 2x joists with plywood sheathing, sometimes with lightweight concrete topping.*

*Roofs of 2x joists with plywood sheathing.*

*At the ground floor parking or open area, steel pipe columns or wood posts supporting a glulam or large dimensional lumber (or sometimes a steel wide flange) header.*

*The provision refers to "all existing wood-frame buildings." Design practice in the Los Angeles area changed after the 1994 Northridge earthquake, but modified building codes did not directly address the fundamental performance issues of SWOF buildings. Recent research has revealed potential deficiencies even in designs using the post-Northridge codes (CUREE, 2002) and may lead to more restrictive code requirements.*

*The provision refers to residential occupancies only. SWOF buildings can also be used for commercial or mixed occupancy. The words "or portions thereof" are intended to cover mixed-use buildings. For example, an apartment building in which the first story with the SWOF condition is occupied entirely by retail is still within the scope of this chapter. At the option of the owner, the Chapter 4 provisions may also be used for SWOF buildings with only commercial occupancy.*

## **GUIDELINES FOR SEISMIC RETROFIT OF EXISTING BUILDINGS**

*The provision refers to SWOF wall lines “as defined in this chapter.” The Chapter 4 definitions, given in section 402, differ somewhat from the similar definitions in the 1997 UBC and 2003 IBC.*

*Condition number 1 is intended to capture the typical tuckunder building described above. One-story buildings are exempt because the principal risk from SWOF buildings is due to collapse of the first story under the weight of upper stories. Also exempt are non-wood-frame conditions, such as buildings in which the walls around the open parking area are concrete or reinforced masonry for the full story height.*

*Condition number 2 is intended to capture the most deficient multi-story buildings without open-front wall lines. These would include, for example, a 3-story building with large open areas on the ground floor, only stucco-braced perimeter shear walls, and few interior partitions to stiffen the first story. (Section 402 defines nonconforming structural materials.) Two-story houses over stucco-braced cripple walls would not be covered by this condition, however, because single-family houses are outside the scope of the chapter. (Such a house might be covered by GSREB Chapter 3.)*

*Condition number 2 refers to wood basement walls. Since wood framing is almost never used for basement or retaining walls, this reference may be understood to mean the above-grade portion of a story that is only partly below grade.*

*Though not explicitly stated, condition number 2 is intended to apply only when the nonconforming material is part of the soft or weak wall line. Nonconforming materials are defined in section 402.*

*Though not explicitly stated, a multistory building might be exempted if the portion of the building with the SWOF condition is distinct from the rest of the building and does not fall into either of the two listed categories. That is, “levels above” may be reasonably understood to mean “stories above and influenced by the SWOF condition.” For example, a 3-story building with a 1-story parking wing might be exempt if the SWOF condition occurs only in the 1-story portion of the building. Such an interpretation requires engineering judgement and might be subject to the approval of the Building Official.*

*The provision defines the threshold ground motion hazard in two ways.  $S_{DI}$  is a seismicity parameter used by the IBC and other model codes based on ASCE 7-02. The  $S_{DI}$  criterion given would cover all buildings in Seismic Design Category D or E, as defined in those codes (Seismic Design Category F is for special occupancies outside the scope of GSREB Chapter 4). Seismic Zones are used to represent seismicity levels in the UBC. The intention of the provision is that only the Building Code needs to be checked. It is not the intention that users must check more than one document.*

*While the provision is written to exempt buildings in low and moderate seismic zones, Chapter 4 may also be used for similar buildings subject to lower hazards.*

### **SECTION 402 DEFINITIONS**

Notwithstanding the applicable definitions, symbols and notations in the Building Code, the following definitions shall apply for the purposes of this chapter:

*In general, “the Building Code” means the codes, standards, regulations, and interpretations in effect in a specific jurisdiction. States and local jurisdictions typically adopt, and sometimes modify, a model code. GSREB Chapter 4 refers in some places to the 1997 UBC and 2000 IBC, which are model codes. References to “this code” or “current code” should be understood as references to “the Building Code.”*

**APARTMENT HOUSE.** Any building or portion thereof that contains three or more dwelling units. For the purposes of this chapter, “apartment house” includes residential condominiums.

## **GUIDELINES FOR SEISMIC RETROFIT OF EXISTING BUILDINGS**

**ASPECT RATIO.** The span-width ratio for horizontal diaphragms and the height-length ratio for vertical diaphragms.

**CONGREGATE RESIDENCE.** A congregate residence is any building or portion thereof for occupancy by other than a family that contains facilities for living, sleeping and sanitation as required by this code, and that may include facilities for eating and cooking. A congregate residence may be a shelter, convent, monastery, dormitory, fraternity or sorority house, but does not include jails, hospitals, nursing homes, hotels or lodging houses.

**CRIPPLE WALL.** A wood-frame stud wall extending from the top of the foundation wall to the underside of the lowest floor framing.

**DWELLING UNIT.** Any building or portion thereof for not more than one family that contains living facilities, including provisions for sleeping, eating, cooking and sanitation as required by this code, or congregate residence for 10 or fewer persons.

**EXPANSION ANCHOR.** An approved mechanical fastener placed in hardened concrete that is designed to expand in a self-drilled or pre-drilled hole of a specified size and engage the sides of the hole in one or more locations to develop shear and/or tension resistance to applied loads without grout, adhesive or drypack.

*“Approved” means approved by the Building Official. Expansion anchors used to resist earthquake effects should also have ICC-ES or equivalent approval. Though the definition says “hardened concrete,” expansion anchors may also be used, where approved, in grouted reinforced masonry.*

*An expansion anchor might also include an appropriate washer and nut as required by manufacturer’s instructions. In addition, plate washers are required for some conditions (in both new construction and retrofit) to help prevent splitting of sill plates. Sill plate damage is best prevented by proper design, location, and installation of hold-downs. Still, plate washers are recommended near ends of shear walls.*

*Installation of expansion anchors can crack weak or deteriorated concrete. Chemical, undercut, or threaded screw-type anchors might be useful in these conditions. A chemical anchor may be used to resist shear and/or tension loads; it uses a structural adhesive (e.g., epoxy) to secure the metal fastener to the sides of a pre-drilled hole in hardened concrete or masonry. An undercut anchor, without grout or adhesive, may also be used to resist shear and/or tension; when tightened, it engages the sides and undercut surfaces of a specially pre-drilled hole in hardened concrete or masonry. Screw-type anchors self-thread a predrilled hole in hardened concrete and resist forces through the mechanical interlock of the anchor threads with the concrete.*

**GROUND FLOOR.** Any floor within the wood-frame portion of a building whose elevation is immediately accessible from an adjacent grade by vehicles or pedestrians. The ground floor portion of the structure does not include any level that is completely below adjacent grades.

**GUESTROOM.** Any room or rooms used or intended to be used by a guest for sleeping purposes. Every 100 square feet (9.3 m<sup>2</sup>) of superficial floor area in a congregate residence shall be considered a guestroom.

**HOTEL.** Any building containing six or more guestrooms intended or designed to be used, rented, hired out to be occupied, or that are occupied, for sleeping purposes by guests.

**LEVEL.** A story, basement or underfloor space of a building with cripple walls exceeding 4 feet (1219 mm) in height.

**LIFE SAFETY PERFORMANCE LEVEL.** The building performance level that includes significant damage to both structural and nonstructural components during a design earthquake, though at least some margin against either partial or total structural collapse remains. Injuries may occur, but the level of risk for life-threatening injury and entrapment is low.

## **GUIDELINES FOR SEISMIC RETROFIT OF EXISTING BUILDINGS**

*Aside from its definition, this term is not used in the text of Chapter 4. As discussed in the commentary to section 401.1, the performance objective of Chapter 4 is Risk Reduction, not Life Safety. A Risk Reduction design addresses only the most egregious deficiencies. It is not as comprehensive as a Life Safety design, but it might achieve the same result if the SWOF condition is the only significant deficiency in the building.*

**LODGING HOUSE.** Any building or portion thereof containing at least one but not more than five guest rooms where rent is paid in money, goods, labor or otherwise.

**MOTEL.** Motel shall mean a hotel as defined in this chapter.

**MULTIUNIT RESIDENTIAL BUILDINGS.** Hotels, lodging houses, congregate residences and apartment houses.

**NONCONFORMING STRUCTURAL MATERIALS.** Wall bracing materials other than wood structural panels or diagonal sheathing.

*This term is used only to define the scope of Chapter 4 in section 401.2. By this definition, materials currently permitted for new construction by model codes such as the 1997 UBC and 2003 IBC are designated as nonconforming.*

*The Los Angeles and Fremont provisions for SWOF buildings (Los Angeles, 1999; Fremont) define nonconforming structural materials as any that are no longer permitted for new construction or any whose design values (allowable shear or aspect ratio) have been reduced since construction. Those standards are therefore more restrictive than the provisions given in Chapter 4.*

*Here, for purposes of identifying SWOF conditions in section 401.2, wood structural panels and diagonal sheathing are given more credit than other bracing methods such as let-in bracing, stucco (Portland cement plaster), or straight sheathing. Though deemed “conforming,” it is possible that plywood or diagonal sheathing, even in buildings from the 1970s and 1980s, will not meet current (i.e. post-Northridge) requirements for new construction (for example, in terms of material specifications, hold-downs, or nailing).*

**OPEN-FRONT WALL LINE.** An exterior wall line, without vertical elements of the lateral-force-resisting system, that requires tributary seismic forces to be resisted by diaphragm rotation or excessive cantilever beyond parallel lines of shear walls. Diaphragms that cantilever more than 25 percent of the distance between lines of lateral-force-resisting elements from which the diaphragm cantilevers shall be considered excessive. Exterior exit balconies of 6 feet (1829 mm) or less in width shall not be considered excessive cantilevers.

*“Without vertical elements” may be understood to mean wall lines without vertical elements sufficient to resist tributary loads in the absence of diaphragm rotation. If there are insufficient elements of the seismic force-resisting system along a given diaphragm edge, then the wall line along that edge must meet the cantilever criteria of this definition or be considered “open.”*

*More important than the solid wall length, though harder to calculate, is the reliance on diaphragm rotation or diaphragm cantilever. The Open Front condition is largely a proxy for torsional irregularity, defined variously in 1997 UBC Table 16-M, 2000 IBC Table 1616.5.1, 2003 IBC Table 1616.5.1.1 and ASCE 7-02 Table 9.5.2.3.2. Torsional irregularity is often considered to be a concern only in rigid diaphragm structures. However, CUREE research has shown that torsion, or diaphragm rotation, contributes significantly to excessive drift along the open wall line, even in buildings with wood diaphragms (CUREE, 2002). In lieu of difficult drift calculations for a semi-rigid diaphragm that would be needed to determine torsional irregularity, the provisions use the more prescriptive definition of Open Front Wall Line.*

*Figure C4-1 illustrates the 25 percent calculation, which compares the cantilever length,  $c$ , to the backspan length,  $b$ . If  $c/b$  exceeds 0.25, the cantilever is considered excessive, and Line A is considered an open-front wall line. The 25 percent value is derived from judgement for consistency with previous code provisions, not from testing, analysis,*

## **GUIDELINES FOR SEISMIC RETROFIT OF EXISTING BUILDINGS**

*or performance statistics. See section 403.10 and its commentary for additional discussion of cantilevered diaphragms.*

*Exit balconies are excluded because, in typical configurations, the outside edge of the balcony does not carry substantial gravity loads from the roof or stories above.*

**RETROFIT.** An improvement of the lateral-force-resisting system by alteration of existing structural elements or addition of new structural elements.

**SOFT WALL LINE.** A wall line whose lateral stiffness is less than that required by story drift limitations or deformation compatibility requirements of this chapter. In lieu of analysis, a soft wall line may be defined as a wall line in a story where the story stiffness is less than 70 percent of the story above for the direction under consideration.

*While the definition is for an individual wall line, the default calculation is for an entire story. According to the definition, if the story is soft in a given direction, then each wall line in that direction is considered a soft wall line. It is probably more appropriate, however, to consider individual wall lines, and to compare the stiffness of a given wall line with the corresponding wall line in the story above. The 70 percent value is consistent with similar definitions in the 1997 UBC, the 2003 IBC, and ASCE 7-02.*

*For purposes of this definition, story stiffness should not include contributions from walls or partitions of "nonconforming structural materials." Walls with hold-downs will be far stiffer than walls subject to rocking or uplift due to a lack of hold-downs. If some wall lengths are provided with hold-downs while others are not, then only those with hold-downs and those with enough gravity load to resist uplift under design level seismic forces should be counted toward the story stiffness.*

*Unless conservative assumptions regarding materials and details are made, stiffness calculations for partitions and other elements not shown on plans will likely require destructive investigation per section 406.3. This can be disruptive and expensive. The relative stiffness of existing plywood can be estimated from procedures given in references such as FEMA 356.*

*For purposes of comparing the stiffness of adjacent stories, any reasonable material and fixity assumptions are acceptable, as long as similar assumptions are made for the two stories being compared and as long as the calculation is not given credit for undue precision. For simplicity, elastic (i.e. uncracked, non-degraded) stiffnesses may be used, and partitions and shear walls may be assumed fixed at the ground and floor levels with respect to in-plane rotation. Based on 1997 UBC Table 16-L and the Exception to section 1629.5.3 item 2, only the lateral stiffness must be considered; that is, story stiffness may be calculated ignoring torsional effects.*

**STORY STRENGTH.** The total strength of all seismic-resisting elements sharing the same story shear in the direction under consideration.

*It is preferable to calculate element capacity based on strength values. For purposes of comparing the strengths of adjacent stories, however, allowable stresses may be used.*

**WALL LINE.** Any length of wall along a principal axis of the building used to provide resistance to lateral loads. Parallel wall lines separated by less than 4 feet (1219 mm) shall be considered one wall line for the distribution of loads.

*"Separated by less than 4 feet" refers to "out-of-plane" separation, for example where part of a wall line is recessed for architectural purposes. A given wall line might consist of several individual non-contiguous shear wall panels separated "in-plane" by large door or window openings or by other architectural elements.*

## GUIDELINES FOR SEISMIC RETROFIT OF EXISTING BUILDINGS

**WEAK WALL LINE.** A wall line in a story where the story strength is less than 80 percent of the story above in the direction under consideration.

*While the definition is for an individual wall line, the calculation is for an entire story. According to the definition, if the story is weak in a given direction, then each and every wall line in that direction is considered a weak wall line. It is probably more appropriate, however, to consider individual wall lines, and to compare the stiffness of a given wall line with the corresponding wall line in the story above. The 80 percent value is consistent with similar definitions in the 1997 UBC, the 2003 IBC, and ASCE 7-02.*

*For purposes of this definition, story strength is as defined above. Story strength should not include contributions from walls or partitions of “nonconforming structural materials.” Any reasonable material and fixity assumptions are acceptable, as long as similar assumptions are made for the two stories being compared. For simplicity, partitions and shear walls may be assumed fixed at the ground and floor levels with respect to in-plane rotation.*

*These assumptions might be unrealistic, especially if the shear strength is limited by rocking or uplift of piers that lack hold-downs. They are generally considered sufficient, however, for the simple purpose of determining the relative strength of a potentially critical story with respect to the story above.*

*Another potential shortcoming of this definition is that it does not account for different force levels in adjacent stories. In a short building, the first story shear is substantially higher than the second story shear. Thus, even if the two stories have the same strength, the first story will be critical. Therefore, where the lower story is just marginally strong enough to avoid classification as “weak,” a comparison of demand/capacity ratios in adjacent stories is recommended. If the lower story is clearly critical and its seismic force-resisting system does not provide ample ductility, the engineer should consider classifying the story as weak regardless of the definition.*

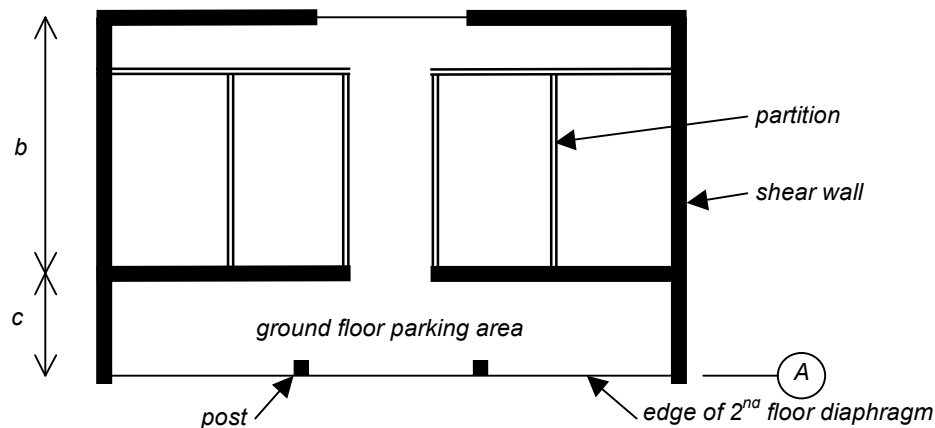

**Figure C4-1. Excessive cantilever calculation.**

# GUIDELINES FOR SEISMIC RETROFIT OF EXISTING BUILDINGS

## SECTION 403 ANALYSIS AND DESIGN

**403.1 General.** Buildings within the scope of this chapter shall be analyzed, designed and constructed in conformance with the 1997 *Uniform Building Code*<sup>™</sup> except as modified in this chapter. Prior to any analysis, an initial screening review of the buildings shall be performed as noted in Section 403.1.1. All items found to be noncompliant shall be addressed in this analysis.

*The first sentence of section 403.1 does not mean that whole buildings must be brought to conformance with the 1997 UBC or the Building Code. Indeed, Chapter 4 and the Building Code have different performance objectives, and certain provisions in Chapter 4 (section 403.2, for example) specifically waive code requirements. Rather, the first sentence intends only that any modifications required by these provisions, principally new structural elements, must be made in accordance with Building Code requirements for new construction.*

*Reference to the 1997 UBC should instead be to the Building Code. The 1997 UBC was the model code used as a reference during development of Chapter 4, but it is not necessarily the Building Code.*

*Despite use of the word “shall” in the second sentence, this provision means only to suggest the sequence of work. Analysis need not be preceded by any screening process. In fact, the screening process in section 403.1.1 is not intended to be mandatory, and items found to be noncompliant (NC) by that process do not necessarily need to be modified or remedied so that they become compliant (C). “Shall be addressed in this analysis” means that noncompliant conditions should be considered by the engineer when performing any analysis or design based on Chapter 4. See the commentary to section 403.1.1 for additional discussion of the screening process.*

No alteration of the existing lateral-force-resisting or vertical-load-carrying system shall reduce the strength or stiffness of the existing structure. When any portion of a building within the scope of this chapter is constructed on or into a slope steeper than 1 unit vertical in 3 units horizontal, the lateral-force-resisting system at and below the base level diaphragm shall be analyzed for the effects of concentrated lateral forces at the base caused by this hillside condition.

### Exceptions:

1. Buildings in which all items on the applicable checklist—Tables 4-A through 4-D—are marked compliant.
2. Prescriptive measures provided in Section 405 may be used in two-story buildings of no geometrical irregularity when the roof covering of the structure is of material weighing 5 pounds per square foot (240 N/m<sup>2</sup>) or less; when the aspect ratio of the floor diaphragm meets the current code requirements; and only when deemed appropriate by the building official.

*These are exceptions to the general requirements, not exceptions to the hillside requirements in the immediately preceding sentence.*

*Exception 1: “Checklist” Tables 4-A through 4-D include items that can not be completed without some structural analysis. Thus, Exception 1 does not really reduce the scope of work otherwise required by section 403. In principle, however, Exception 1 offers a prescriptive alternative method: if small modifications to the building can eliminate noncompliant conditions (NC), then a full analysis and retrofit need not be performed. In other words, it is acceptable to modify the building so as to change noncompliant conditions to compliant (C) or not applicable (N/A) and thereby exempt the building from the balance of Chapter 4. Such an approach is advisable only when the noncompliant conditions are very few and remediable by local measures. If substantial demolition, strengthening, or member replacement is required to eliminate one or more noncompliant conditions, a full analysis per section 403 (or section 405, if applicable) is recommended. See the commentary to section 403.1.1 for additional discussion of Tables 4-A through 4-D.*

*Exception 2: Sections 405.1.2 and 405.1.3 further limit the use of the prescriptive provisions in section 405. See the flowchart in Figure C4-4. If the building qualifies for the prescriptive measures in section 405, then the*

## **GUIDELINES FOR SEISMIC RETROFIT OF EXISTING BUILDINGS**

*requirements of section 403—including the weak story limits, drift limits, etc.—are waived. The requirements of sections 406, 407, and 408 would still apply.*

*In Exception 2, “no geometrical irregularity” may be understood to mean no irregularity other than the soft and/or weak story vertical irregularities that the building is presumed to have. Plan and vertical structural irregularities are described in 1997 UBC Tables 16-L and 16-M, 2003 IBC Tables 1616.5.1.1 and 1616.5.1.2, or ASCE 7-02 Tables 9.5.2.3.2 and 9.5.2.3.3.*

*The roofing weight limit of 5 psf is intended to rule out unusually heavy structures to which the prescriptive provisions do not apply. The limit is not intended to rule out the fairly common condition of two asphalt roofings.*

*Limiting diaphragm aspect ratios required by Exception 2 can be found in 1997 UBC section 2315.1 and Table 23-II-G or 2003 IBC Table 2305.2.3. Per Table 4-D, unblocked wood structural panel diaphragms spanning less than 40 ft with aspect ratios up to 4:1 are deemed acceptable.*

**403.1.1 Initial screening.** Prior to any analysis, an initial screening review of the buildings shall be performed.

Each of the evaluation statements on this checklist shall be marked compliant (C), noncompliant (NC), or not applicable (N/A). Compliant statements identify issues that are acceptable according to the criteria of this chapter, while noncompliant statements identify issues that require further investigation. Certain statements may not apply to the buildings being evaluated. For noncompliant evaluation statements, the design professional may choose to conduct further investigation or comply with the prescriptive requirements of this chapter.

*Despite its wording, this provision means only to suggest the sequence of work. Analysis need not be preceded by any screening process. In fact, the screening process in section 403.1.1 is not intended to be mandatory, and items found to be noncompliant (NC) by that process do not necessarily need to be modified or remedied so that they become compliant (C).*

*In the second paragraph, “this checklist” means Tables 4-A through 4-D, which were adapted from FEMA 310 (ASCE, 1998). Reference in the last sentence to “prescriptive requirements” means those in section 405, which are allowed only in certain conditions that might or might not be related to the noncompliant evaluation statements. The words “may choose” do not necessarily mean that 405 may be used in lieu of 403. See the flowchart in Figure C4-4.*

*The screening procedure, using the “checklist” comprising Tables 4-A through 4-D, has two purposes. First, as discussed in the commentary to section 403.1 Exception 1, it can be used to identify buildings that are already nearly compliant and require only the correction of one or two small deficiencies. In these cases, the full analysis and retrofit design otherwise contemplated by Chapter 4 can be avoided. Second, the checklist is recommended as a way for the designer to become familiar with the building and any likely weak links in its seismic force resisting system and load path without the comprehensive investigation and analysis that might be required for more than a Risk Reduction effort.*

*The presumption of the Risk Reduction approach of Chapter 4 is that the SWOF condition is by far the most egregious seismic deficiency in the building. Given that presumption, many of the lesser deficiencies listed in the checklist Tables, which are geared toward Life Safety performance, need not be corrected to achieve the basic Risk Reduction. However, if certain conditions are found to be noncompliant, the designer might choose to account for them in the analytical model and detailing. For example, the Risk Reduction analysis, focused on the SWOF condition, might not check the connections of walls through floors (Table 4-B) or the adequacy of sill bolts (Table 4-C). If those conditions are indeed noncompliant, the designer might find that they represent the next weakest links after the SWOF, and that it might be cost-effective to include them in the project scope. Nevertheless, remedies for any conditions outside the scope of section 403.2 (or section 405, where applicable) are optional.*

*When Tables 4-A through 4-D are used to check section 403.1 Exception 1, the following apply:*

*If an item can not be marked C due to unknown conditions, it is to be marked NC.*

*If an item is marked NC due to unknown conditions or conservative assumptions, additional inspections or testing may be used to reveal compliant conditions.*

## GUIDELINES FOR SEISMIC RETROFIT OF EXISTING BUILDINGS

*Details and materials used to remedy any NC condition must be in conformance with the Building Code.*

**403.2 Scope of analysis.** This chapter requires the alteration, repair, replacement or addition of structural elements and their connections to meet the strength and stiffness requirements herein. The lateral-load-path analysis shall include the resisting elements and connections from the wood diaphragm above any soft, weak or open-front wall lines to the foundation soil interface or the upper level of a Type I structure below. The top story of any building need not be analyzed. The lateral-load-path analysis for added structural elements shall also include evaluation of the allowable soil-bearing and lateral pressures in accordance with UBC Section 1805.

*This paragraph distinguishes Chapter 4's Risk Reduction objective from a full Life Safety objective. Using Chapter 4, the only structural elements that need consideration are those between the diaphragm above a SWOF story and the foundation soil. Stories above that level need not be checked. Further, if the wood-frame SWOF structure sits on a separate steel, concrete, or masonry podium structure (a below-grade parking garage, for example), that Type I podium structure need not be checked. (Type I refers to certain fire resistive buildings described in 1997 UBC section 602. The numeral should be a Roman I. Other codes may use different designations or have different requirements for Type I construction.)*

*Top stories are exempt for the same reason that 1-story buildings were exempted in section 401.2. These provisions focus on the specific risks posed by the collapse of SWOF stories with substantial mass above. When the SWOF story collapses, it is the crushing action of the falling upper stories that poses the greatest risk. Racking or excessive drift in a 1-story SWOF building or in the top story of a SWOF building are of lesser concern.*

*Soil stresses need only be checked where they are affected by "added structural elements" such as walls, diagonal braces, frame columns, posts, or other structural elements added as part of the retrofit. Where allowable soil stresses are exceeded due to these added elements, foundation elements will need to be supplemented as well.*

*"UBC Section 1805" refers to the 1997 UBC provision that gives default allowable soil bearing and lateral pressures. The reference may be understood to refer to the corresponding requirements of the Building Code. The reference to default allowable stresses is not intended to prohibit the use of higher design values substantiated by testing or geotechnical investigation. UBC section 1805 gives allowable pressures suitable for use with allowable stress design procedures. The design forces prescribed in section 403 are at a strength level, however, so appropriate adjustments may be made by increasing the allowable soil pressures for short-term loading and by reducing the prescribed design forces to allowable stress levels.*

*UBC Table 18-I-A, referenced by section 1805, allows a 33 percent increase in allowable pressures for load combinations that include earthquake effects. By contrast, GSREB section 108.6 allows an effective increase of 50 percent. Because each chapter of the GSREB was developed independently, it is recommended that only the 33 percent increase should be used in Chapter 4. Higher allowable pressures may be used when substantiated by testing or geotechnical investigation.*

**Exception:** When an open-front, weak or soft wall line exists because of parking at the ground level of a two-level building, and the parking area is less than 20 percent of the ground floor level, then only the wall lines in the open, weak or soft directions of the enclosed parking area need comply with the provisions of this chapter.

*This exception further reduces the scope of Chapter 4 for SWOF deficiencies that are judged to be remediable by local measures. Again, the Risk Reduction approach acknowledges that when the most critical deficiencies are easily identified and remedied, comprehensive analysis of the entire structure should not be necessary.*

*The exception is intended to cover a large subclass of SWOF buildings with minimal tuckunder parking. While the provision specifically mentions "parking," it could be reasonably applied to similar unoccupied spaces used for storage or other purposes. The 20 percent value is derived from judgement, not from testing, analysis, or performance statistics. Use of the term "enclosed parking area" is intended to indicate a defined area bounded in plan by walls, partitions, or the edge of the building; it does not mean that the parking (or other non-occupiable) area must be physically enclosed.*

## GUIDELINES FOR SEISMIC RETROFIT OF EXISTING BUILDINGS

The 20 percent value is to be based on floor area. All non-occupiable area (as opposed to just designated parking area) between the SWOF wall line and the nearest parallel wall line should be counted as the "parking area." Figure C4-2 shows the type of common SWOF building for which this exception was intended. Other configurations are also eligible for the exception. For complex floor layouts, designation and calculation of the parking area might require some judgement.

With reference to Figure C4-2, Line A is assumed to be a SWOF wall line. Line B is the nearest parallel wall line. if  $A_P/(L_x L_y)$  is less than 0.20, then only wall lines A and B need to be checked and potentially strengthened or stiffened.)

The intention of this exception is only to exempt wall Lines C, 1, and 2 from drift and strength requirements. These wall lines must still be included in the structural model used to derive forces and deflections for Lines A and B. In considering Lines A and B, the load path from the second floor diaphragm to the soil-foundation interface must still be checked per section 403.2.

This exception does not apply if the prescriptive provisions of section 405 are used.

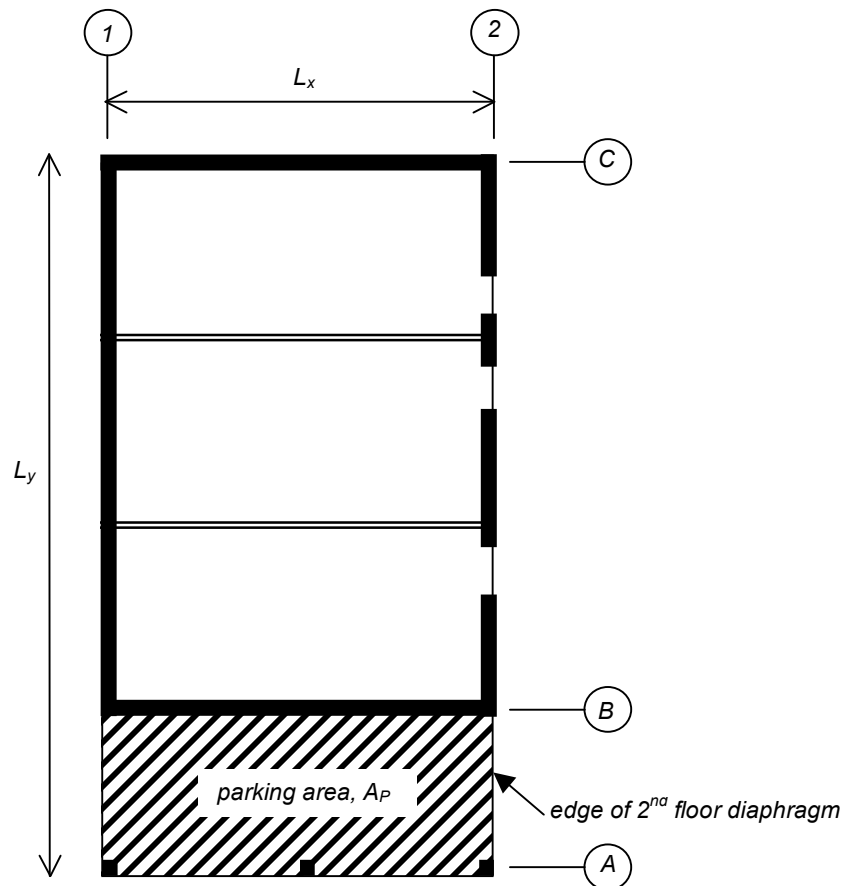

**Figure C4-2. 20 percent exception calculation.**

**403.3 Design base shear.** The design base shear in a given direction shall be 75 percent of the value determined by Formulas (30-4) through (30-7) in UBC Section 1630.2.

The 75 percent value represents a common allowance for existing buildings with precedent in FEMA 178 (1992). FEMA 178 specified a design base shear of 85 percent (for short period buildings) or 67 percent (for longer period

## **GUIDELINES FOR SEISMIC RETROFIT OF EXISTING BUILDINGS**

buildings) of that required for new construction. At the time, the reduction was said to be related to the difference between a “mean” earthquake and a “probable” earthquake. It is not clear whether that relationship still holds for the seismicity estimates and design parameters in current codes. Nevertheless, a reduction of about 25 percent remains traditional and is consistent with 2003 IEBC section 407.1.1.3.

“Formulas (30-4) through (30-7) in UBC Section 1630.2” refers to the 1997 UBC provision that specifies the minimum total base shear for design using the static (equivalent lateral force) procedure. The reference may be understood to refer to the corresponding requirements of the Building Code. These base shear formulas lead to design forces suitable for strength (as opposed to allowable stress) design procedures.

In order to use UBC formulas 30-4 through 30-7, one must know the Seismic Zone and the Soil Profile Type. The UBC allows Soil Profile Type D to be used by default, subject to approval by the Building Official. Soft clays and poorly compacted deep fills are likely to need site-specific investigation. (See Stewart et al., 1995, regarding the historic performance of fills.) In Zone 4, one must also know the Seismic Source Type and the distance from the site to the seismic source. In order to use the corresponding formulas in the 2003 IBC or ASCE 7-02, one must know the soil type (called the Site Class) and have access to large-scale or computerized maps of seismicity parameters. Due to small differences in the formulas for building period and base shear, the design base shear may vary depending on which Building Code or model code is used. These differences, and the consequent variations in base shear, are considered negligible for the purposes of Chapter 4. Differences in the various codes’ prescribed R values, however, might be more significant. Still, the design criteria from any recent should be acceptable.

The design base shear also depends on the structure’s seismic force-resisting system and its R factor. The R factor for existing systems should be chosen with due consideration of the age and quality of construction, as well as the condition of the structure. R factors assigned by the Building Code for new construction presume certain standards for materials, connections, detailing, and quality control that might not be met by the existing structure. In those cases, a modification to the tabulated R factor might be warranted. Chapter 4 section 406 gives requirements for the condition of existing materials. As for obsolete detailing (inadequate fastener spacing or member size, for example), engineering judgement, supported by appropriate research, analysis, and material testing will often be needed.

With respect to existing systems comprised of light-framed walls braced by stucco or let-ins (that is, without wood structural panels), different codes might assign significantly different R factors. The 1997 UBC would allow an R of 4.5 (Table 16-N, system type 1.1.b), but ASCE 7-02 and codes based on it would allow only R of 2 (Table 9.5.2.2). Provisions of the Building Code should apply.

A retrofitted SWOF building will frequently involve combinations of different systems. Refer to section 403.4 and its commentary for discussion of R factors for combined systems common to retrofitted SWOF buildings.

The Building Code may place limits on static procedures such as those prescribed by Chapter 4. In general, these limits should be heeded even for analysis of existing buildings. (For example, 1997 UBC section 1629.8.3 allows the static procedure only for SWOF buildings up to five stories or 65 feet tall. It also prohibits use of the static procedure for SWOF wood buildings on top of stiff podium structures because the SWOF portion is irregular. Thus, the static procedure might not be appropriate for evaluation of the existing wood building in these cases.)

The simplified design procedure (1997 UBC section 1630.2.3; ASCE 7-02 section 9.5.4) is considered an acceptable conservative alternative to UBC formulas 30-4 through 30-7. The 75 percent multiplier may be applied to the simplified base shear formula. The Building Code may place limits on simplified procedures, however, and these limits should be heeded even for analysis of existing buildings. (For example, 1997 UBC section 1629.8.2 allows the simplified procedure only for light frame buildings up to three stories and other structure types up to two stories. Thus, the simplified procedure might not be appropriate for analysis of a three-story building retrofitted with a steel frame or masonry shear wall in the first story. In addition, while UBC section 1630.2.3.3 allows distribution of design forces by story weight when the simplified base shear is used, GSREB section 403.4 limits this to two-story buildings.)

**403.4 Vertical distribution of forces.** The total seismic force shall be distributed over the height of the structure based on the Formula (30-15) in UBC Section 1630.5. Distribution of force by story weight shall be permitted for

## GUIDELINES FOR SEISMIC RETROFIT OF EXISTING BUILDINGS

two-story buildings. The value of  $R$  used in the design of any story shall be less than or equal to the value of  $R$  used in the given direction for the story above.

*“Formula (30-15) in UBC Section 1630.5” refers to the 1997 UBC provision that prescribes the distribution of design forces over the structure height when the static (equivalent lateral force) procedure is used. The reference may be understood to refer to the corresponding requirements of the Building Code. The “total seismic force” is equivalent to the “design base shear” calculated according to section 403.3.*

*“Distribution of force by story weight” refers to an alternate method such as that given by 1997 UBC formula 30-12 for use with the simplified design procedure. As discussed in the commentary to section 403.3, simplified design base shear formulae are considered acceptable alternatives. Model codes sometimes allow the use of simplified design for buildings taller than two stories. According to Chapter 4 section 403.4, however, the force distribution by story weight may only be used for two-story buildings.*

*A retrofitted SWOF building will frequently involve combinations of different seismic force-resisting systems. The existing wood-frame SWOF building will likely be classified as a bearing wall system of light-framed walls with either wood structural panels or stucco bracing. Structural elements commonly added for retrofit might be steel moment resisting frames or building frame systems with wood structural panels, concrete or masonry shear walls, or steel diagonal braces. In the retrofitted building, systems might be combined in various ways: vertically (that is, with different systems in different stories), within the same story along different wall lines or in different directions, or within the same story along the same wall line. The  $R$  factor for a given combination should be determined based on the provisions of the Building Code.*

*Provision 403.4 provides a rule for use when systems are combined vertically. This rule is essentially the same as that provided in 1997 UBC section 1630.4.2. For new construction, the purpose of this rule is to avoid concentrated inelasticity in lower stories by delaying yield in the lower story until the upper story is also near its elastic limit. For SWOF retrofits, however, it might make more sense to concentrate inelasticity in the new, properly-detailed elements so that ductility can be provided and controlled by design.*

*Consider, for example, a typical three-story tuckunder building with an open front wall line along one side in the first story and stucco-braced walls in the upper stories. According to Chapter 4 section 403.2, only the second floor diaphragm and the first story wall lines need to be considered for Risk Reduction. If a steel frame is to be installed in the open wall line, it seems entirely reasonable to design it as the building’s primary source of ductility, with an  $R$  factor of 4.5 (or even higher if special detailing is provided). After all, the brittle upper story stucco walls are not going to be touched by the retrofit, and they can not be made worse by the presence of a ductile frame below. It may seem overly conservative to select a ductile system for retrofit and then design it for a low  $R$  factor, in this case only 2 (according to ASCE 7-02). Indeed, one could argue that use of a low  $R$  factor could result in a very strong first story that could force failure up into the second story.*

*Nevertheless, the provision is plain as to its intent, and until further studies are performed, the provision should be followed as written. That is, the  $R$  factor for the design of new structural elements should be limited by the existing structure in stories above. Further, the use of a low  $R$  factor based on upper stories does not excuse the new elements from proper detailing. That is, if a steel frame with  $R$  of 4.5 is installed, then it must be detailed as required for  $R$  of 4.5 even if its members are sized for forces based on  $R$  of 2.*

**403.5 Weak story limitation.** The structure shall not exceed 30 feet (9144 mm) in height or two levels if the lower level strength is less than 65 percent of the story above. Existing walls shall be strengthened as required to comply with this provision unless the weak level can resist a total lateral seismic force of  $\frac{1}{3}$  times the design force prescribed in Section 403.4.

The story strength for each level of all other structures shall be a minimum of 80 percent of the story above.

*The reference to Section 403.4 may be understood to mean the force prescribed in section 403.3 and distributed according to section 403.4.*

## GUIDELINES FOR SEISMIC RETROFIT OF EXISTING BUILDINGS

“Existing walls shall be strengthened” is not meant to prohibit other means of mitigating the weak story. For example, existing walls may be replaced, or new walls or other structural elements may be added.

“[T]he weak level can resist” means “the weak story strength is not less than.”

This provision is based on a requirement for new construction (1997 UBC section 1629.9.1; similarly, 2000 IBC section 1620.1.3) which allows weak stories in some buildings, subject to certain limitations. Applied to existing buildings, this provision sets the minimum strength requirements for retrofit when a weak story exists. It says that for a building up to the 2-story and 30-ft limits, the weak story must be strengthened to at least 65 percent of the strength of the story above—but the weak story is still allowed to be weak by the 80 percent definition, even in its retrofitted condition. For other buildings, the strength must be brought to 80 percent of the story above; that is, the weak story must be completely eliminated. In essence, this provision allows a weak story to remain in small buildings, as long as it is not excessively weak.

The overstrength exception applies to any weak story in a building of any height. That is, a weak story need only be strengthened to the lesser of: 1.  $1.0$  times the story shear prescribed by Sections 403.3 and 403.4, or 2. some percentage of the strength of the story above (either 65 percent or 80 percent), depending on the height of the building.

Consider a two-story building in which the weak first story has 70 percent of the strength of the second story. Section 403.5 does not necessarily exempt this building from consideration. While its first story strength is adequate, the building still qualifies for consideration by section 401.2 and must therefore still meet the stiffness, load path, and diaphragm requirements of section 403 (or the prescriptive provisions of section 405, if they apply).

Whether a weak story should be allowed in even a two-story retrofitted building is a fair question. The 1997 UBC, as noted above, allows weak stories in some buildings. As a rule, retrofit provisions should not be more restrictive than the code for new construction. On the other hand, in new buildings the seismic load path is detailed to full code-level forces, the materials are controlled, and the construction is inspected. Since this is not the case for retrofit, one could argue that the GSREB provision should seek to eliminate all weak stories. Indeed, section 1620.4.1 of the 2000 IBC, section 1620.5.1 of the 2003 IBC, and ASCE 7-02 section 9.5.2.6.5.1 prohibit all weak stories for new buildings in Seismic Design Category E, which covers much of coastal California (wherever  $S_1$  is 0.75g or greater). Until further studies are performed, the provision is accepted on the basis that provisions somewhat less stringent than the Building Code may be acceptable for Risk Reduction in two-story buildings.

While section 403.5 sets the minimum strength requirements for retrofit of existing weak stories, minimum stiffness requirements are given by section 403.6. There is no similar provision that allows a soft story to remain in a two-story building.

**403.6 Story drift limitation.** The calculated story drift for each retrofitted level shall not exceed the allowable deformation compatible with all vertical-load-resisting elements and 0.025 times the story height. The calculated story drift shall not be reduced by the effects of horizontal diaphragm stiffness but shall be increased when these effects produce rotation. Drift calculations shall be in accordance with UBC Section 1630.9 and 1630.10.

“UBC Section 1630.9 and 1630.10” refers to the 1997 UBC provisions for calculating interstory drift and drift limitations. The reference may be understood to refer to the corresponding requirements of the Building Code. GSREB Chapter 4 section 403.11.2.1 makes additional requirements for drift calculation in wood shear walls.

Where the Building Code is based on the 1997 UBC, “The calculated story drift” means the difference between the Maximum Inelastic Response Displacement,  $\Delta_M$ , at floor levels above and below the story in question. As defined in 1997 UBC section 1630.9.2,  $\Delta_M = 0.7 R \Delta_S$ , where  $\Delta_S$  is the drift calculated from a linear elastic analysis using the forces prescribed in Chapter 4 section 403.3. P $\Delta$  effects must be included in the analysis as required by section 403.7 (by reference to 1997 UBC section 1630.1.3).

Where the Building Code is based on ASCE 7-02, “The calculated story drift” means the design story drift as defined in section 9.5.5.7.1, based on center of mass deflections,  $\Delta_{xe}$ , calculated from a linear elastic analysis using

## **GUIDELINES FOR SEISMIC RETROFIT OF EXISTING BUILDINGS**

*the forces prescribed in Chapter 4 section 403.3. P $\Delta$  effects must be included in the analysis as required by section 403.7 (by reference to corresponding ASCE 7-02 section 9.5.5.7.2).*

*Since an erratum dated March 2001, 1997 UBC section 1630.10.3 allows drifts to be calculated without the base shear limits of formula 30-6 and 30-7. ASCE 7-02 section 9.5.5.7.1 allows the first of its corresponding equations (9.5.5.2.1-3) to be ignored, but not the second. In any case, this exclusion is not expected to come into play for typical SWOF buildings within the scope of Chapter 4. Further discussion of the issue can be found in Seismology (2004).*

*“[E]ach retrofitted level” means each story subject to consideration according to section 403.2. Drifts need not be checked at stories above the SWOF conditions. Once the analysis is performed, however, it is usually a trivial matter to check the drifts at upper stories. Indeed, the definition of a Soft Wall Line in section 402 is based on calculated story drifts. According to that definition, the “70 percent rule” is acceptable as an alternative to analysis, so even if drift limits are exceeded, the story need not be classified as Soft if it meets the 70 percent rule. In this case, engineering judgement should be used to determine whether flexible upper stories need to be stiffened for acceptable performance.*

*The limiting drift ratio of 0.025 corresponds to the limit for low- and mid-rise buildings in 1997 UBC section 1630.10.2. The 2003 IBC limit, based on ASCE 7-02 Table 9.5.2.8, for most low-rise buildings is also 0.025, but only where “partitions, ceilings, and exterior wall systems” can accommodate that deformation. Most existing SWOF buildings should not be assumed to meet that criterion, so the IBC would limit the drift ratio to 0.02. Studies by CUREE (2002) have suggested that allowable drifts should be lowered even further for open-front wood-frame buildings analyzed with the static (equivalent lateral force) procedure.*

*Also, ASCE 7-02 sets limits lower than 0.025 for masonry shear wall structures. If masonry shear walls are added as retrofit elements, these lower drift limits should be considered.*

*The provision does not define the “allowable deformation compatible with all vertical-load-resisting elements.” Vertical load resisting elements in a typical wood-frame SWOF building include stud walls and partitions, sheathed or braced with plywood, stucco, plaster, gypsum board, or gypsum lath. If the materials are in good condition, a limit of 0.02 for these elements should be appropriate, based on ASCE 7-02 Table 9.5.2.8. Many existing SWOF buildings also have wood posts or steel pipe columns along the open side. For these, the limit of 0.025 is judged appropriate unless their condition is poor (rotted or corroded) or their connections are unable to accommodate that much deformation. SWOF buildings within the scope of Chapter 4 would not be expected to have brittle load-bearing components (unreinforced masonry infill, for example) that would be critical in terms of deformation compatibility. If such components do exist, more stringent drift limits might be appropriate.*

*The provision regarding “horizontal diaphragm stiffness” requires that diaphragms be modeled as rigid relative to the walls so that the effects of actual and accidental torsion can be conservatively estimated. This is most important for evaluation of the existing SWOF, less so for analysis of a building retrofitted with stiff new elements along the SWOF wall line. The rigid diaphragm assumption is supported by recent testing that found the effects of a wood diaphragm on an open-front structure were sufficiently approximated by modeling the diaphragm as a rotating rigid body (CUREE, 2002). While a rigid diaphragm must be assumed for this provision, section 403.10 also appears to require force distribution based on a flexible diaphragm assumption. Chapter 4 thus appears to require design for the more conservative of the two possibilities.*

*The provision to add, but not subtract, the effects of diaphragm rotation is a conservative requirement similar to ASCE 7-02 section 9.5.5.7.1 requirements for buildings with torsional irregularity. In those buildings, the design drift must be calculated at the most critical point along any diaphragm edge. (1997 UBC section 1630.9.1 requires drift to be calculated at all “critical locations” in all structures.) A test structure with obvious open-front deficiencies was tested by CUREE (2002) and performed poorly, as expected; drift calculations at the center of mass, however, would not have predicted a torsional irregularity by the letter of the code.*

The effects of rotation and soil stiffness shall be included in the calculated story drift when lateral loads are resisted by vertical elements whose required depth of embedment is determined by pole formulas, such as Formulas

## GUIDELINES FOR SEISMIC RETROFIT OF EXISTING BUILDINGS

(6-1) and (6-2) in UBC Section 1806.8.2. The range of this coefficient of subgrade reaction used in the deflection calculations shall be provided from an approved geotechnical engineering report or other approved methods.

*The “rotation” referred to here is the rotation of an embedded pole bearing laterally against soil, either with or without restraint at the ground surface by a slab or rigid pavement. The provision is intended to address pipe columns or posts supporting gravity loads along the building’s open side. Pole systems are especially flexible and vulnerable to loss of vertical capacity. This provision applies mostly to analysis of the existing structure; in the retrofitted structure, the lateral stiffness contribution of posts is generally negligible by comparison to the stiffness of new wall, frame, or brace elements.*

*The coefficient of subgrade reaction refers to the stiffness of soil when pressed against by the embedded post. The provision refers to a range of values because an exact value is often difficult to predict with precision and because geotechnical engineers might therefore prefer to report a range of values.*

**403.7 P effects.** The requirements of UBC Sections 1630.13 and 1633.2.4 shall apply except as modified herein. All structural framing elements and their connections not required by design to be part of the lateral-force-resisting system shall be designed and/or detailed to be adequate to maintain support of design dead plus live loads when subjected to the expected deformations caused by seismic forces. The stress analysis of cantilever columns shall use a buckling factor of 2.1 for the direction normal to the axis of the beam.

*“1630.13” is a typographical error. The provision should read “1630.1.3.”*

*1997 UBC section 1633.2.4 requires deformation compatibility checks for structural elements that are not part of the seismic force-resisting system, such as posts, pipe columns, stair framing, and wood-framed walls deformed out of plane. Section 1633.2.4 also requires these checks to include  $P\Delta$  effects. Section 1630.1.3 gives more general requirements for consideration of  $P\Delta$  effects. The provision may be understood to refer to the corresponding requirements of the Building Code.*

*ASCE 7-02 section 9.5.5.7.2 and the 1999 SEAOC Blue Book (SEAOC 1999), section C105.1.3, offer a procedure for incorporating  $P\Delta$  effects into the analysis. The 1999 Blue Book (section C108.2.4 and Appendix E) also offers guidance for accommodating  $P\Delta$  effects in various element types. Inelasticity is permitted when members and connections are checked for  $P\Delta$  effects; the important thing is for the structure to maintain its resistance to gravity loads.*

*In existing SWOF buildings, the most critical elements are probably the posts along the open front, because they often have weak flexural connections and because drift is greatest along that wall line. The design check should rule out any buckling of the post and any failure of base plates or connection hardware that would compromise stability. For cantilever columns or moment frame columns, if  $P\Delta$  effects are included in the analysis, then additional bending stress amplifiers in typical design equations (such as  $1-f_a/F'$ ) need not be applied.*

*The last sentence of the provision refers to typical posts or pipe columns along the open side that are pinned at one end and therefore deform in single curvature: either pinned at the base and rigidly connected at the top or embedded at the base and pinned at the top. The “direction normal to the axis of the beam” generally means the direction normal to the open wall line. “Buckling factor” means the “effective buckling length factor.” If the column is considered pinned at both ends with respect to buckling in any direction, an effective buckling length factor of 1.0 is appropriate. Fixity assumptions depend on the nature and condition of the beam-column connection. For existing posts or pipe columns, the appropriate assumption is generally a matter of engineering judgement.*

**403.8 Ties and continuity.** All parts of the structure included in the scope of Section 403.2 shall be interconnected, and the connection shall be capable of resisting the seismic force created by the parts being connected. Any smaller portion of a building shall be tied to the remainder of the building with elements having a strength to resist 0.5  $C_d I$  times the weight of the smaller portion. A positive connection for resisting a horizontal force acting parallel to the member shall be provided for each beam, girder or truss included in the lateral load path. This force shall not be less than 0.5  $C_d I$  times the dead plus live load.

## GUIDELINES FOR SEISMIC RETROFIT OF EXISTING BUILDINGS

*This provision is based on 1997 UBC section 1633.2.5. Where the Building Code is based on ASCE 7-02 (which does not use the parameter  $C_a$ ), the corresponding provision is in section 9.5.2.6.1.1.*

*In 1997 UBC section 1633.2.5, the 0.5 value in the last sentence of the provision was changed to 0.3 in an erratum dated January 2001. A similar reduction is appropriate for this GSREB provision.*

*As noted in ASCE 7-02, the connection forces prescribed by this provision do not apply to the overall design of the seismic force-resisting system. That is, they need not be added to the design forces prescribed by sections 403.3 and 403.4 for analysis and design of the seismic force-resisting system.*

*The minimum connection strengths required by this provision are prescriptive and are derived from judgement, not from testing, analysis, or performance statistics.*

**403.8.1 Cripple walls.** Unbraced cripple walls found to be noncompliant in Table 4-C shall be analyzed and designed per Chapter 3. When a single top plate exists in the cripple wall, all end joints in the top plates shall be tied. Ties shall be connected to each end of the discontinuous top plate and shall be equal to one of the following:

1. Three-inch-by-6-inch (76 mm by 152 mm), 18-gage galvanized steel, nailed with six 8d common nails at each end.
2. One and one-fourth-inch-by-12-inch (32 mm by 305 mm), 18-gage galvanized steel, nailed with six 16d common nails at each end.
3. Two-inch-by-4-inch-by-12-inch (51 mm by 102 mm by 305 mm) wood blocking, nailed with six 16d common nails at each end.

*The first sentence should refer to Table 4-B, not Table 4-C. Since the use of Table 4-B is not strictly required (see the commentary to section 403.1.1), the first sentence of this provision should be understood to mean that cripple walls braced only by nonconforming materials should be evaluated and retrofitted as necessary.*

*The provision refers to GSREB Chapter 3, which offers prescriptive measures for wood-frame residential structures. However, Chapter 3 is intended principally for houses and explicitly does not apply to hotels and apartment houses with more than four units; these buildings require analysis. The reference to Chapter 3 might also be problematic if its prescriptive measures conflict with the engineered approach of Chapter 4. In general, the procedures of Chapter 4 should be used to evaluate cripple walls as load path elements. Where analysis shows that the existing cripple walls do not comply with Chapter 4's strength and stiffness requirements, the provision allows that the prescriptive measures of Chapter 3, section 304.4 and Table 3-A, may be used to specify retrofit details. If the Chapter 3 provisions do not apply, retrofit details should be designed like any other new structural element, for compliance with the Building Code.*

*The intention of this provision is that multi-story wood-frame buildings with cripple walls should not be deemed compliant just because they do not have obvious SWOF conditions. For example, a large house-like building divided into more than four rental units would not be covered by Chapter 3 and might be missed by Chapter 4 as well, if not for such a provision. Nevertheless, this provision does not apply unless the building is within the scope of the Chapter defined in section 401.2. For the case of the large-house like structure with cripple walls, the cripple story might be classified as soft or weak if it lacks the stiffening partitions of the occupied stories.*

*Perhaps a more common example of a SWOF building with cripple walls involves partial height masonry or concrete basement walls at the lowest level. Short wood-framed stud walls, or cripple walls, are used between the top of the basement wall and the next floor level. In this case, the cripple walls will necessarily be addressed as load path elements if the basement story has a SWOF condition.*

*"Ties" means "splices." Different strap sizes are given to account for different top plate dimensions. Strap splices applied symmetrically to both sides of the top plate are preferred, though not required; symmetric splices will often*

## **GUIDELINES FOR SEISMIC RETROFIT OF EXISTING BUILDINGS**

*be impractical if there is no other reason to remove the exterior finishes. Pre-drilling for nails (with a bit  $\frac{3}{4}$  the diameter of the nail) is recommended for 2x top plates where splitting due to excessive nailing is a concern.*

**403.9 Collector elements.** Collector elements shall be provided that can transfer the seismic forces originating in other portions of the building to the elements within the scope of Section 403.2 that provide resistance to those forces.

*This provision is based on 1997 UBC section 1633.2.6. “[O]ther portions” does not mean elements outside the scope of section 403.2. That terminology remains from the UBC provision for new construction. The intent of this provision is merely to assure adequate collectors within the load path described in section 403.2, that is, from the diaphragm above the SWOF condition to the existing or added components of the seismic force-resisting system.*

*The provision does not specify means for determining design forces for collectors. Acceptable design forces may be derived from formulas such as 33-1 in the 1997 UBC or 9.5.2.6.4.4 in ASCE 7-02, with the applied forces  $F_i$  determined from Chapter 4 sections 403.3 and 403.4. Provisions in section 403.8 set a minimum on this design force.*

*UBC section 1633.2.6 and ASCE 7-02 section 9.5.2.6.3.1 require most collectors to be designed for “special seismic loads” amplified by the factor  $\square_0$ , but they exempt light-framed wood structures. On that basis, the special seismic load combinations are not required for the wood-framed buildings within the scope of Chapter 4. Retrofitted SWOF buildings, however, might have steel, concrete, or masonry systems that require amplified seismic forces. As written, the provision is less specific than the codes, requiring only collectors “that can transfer the seismic forces.” Based on section 403.1, which requires new elements to meet the Building Code, amplified forces should be used for collector design in systems other than light-framed wood.*

**403.10 Horizontal diaphragms.** The analysis of shear demand or capacity of an existing plywood or diagonally sheathed horizontal diaphragm need not be investigated unless the diaphragm is required to transfer lateral forces from the lateral-resisting elements above the diaphragm to other lateral-resisting elements below the diaphragm because of an offset in placement of the elements.

Wood diaphragms in structures that support floors or roofs above shall not be allowed to transmit lateral forces by rotation or cantilever except as allowed by the Building Code. However, rotational effects shall be accounted for when unsymmetric wall stiffness increases shear demands.

**Exception:** Diaphragms that cantilever 25 percent or less of the distance between lines of lateral-load-resisting elements from which the diaphragm cantilevers may transmit their shears by cantilever, provided that rotational effects on shear walls parallel and perpendicular to the load are taken into account.

*Section 403.2 explicitly requires assessment of certain floor diaphragms. The first paragraph of this provision allows an exemption. In essence, diaphragm strength must be checked only when 1. the diaphragm is of straight board sheathing (that is, not plywood or diagonal sheathing), or 2. the diaphragm is on the load path between vertical components of the seismic force-resisting system that are offset at the floor level. In the second case, only the portions of the diaphragm that provide force transfer between the offset elements of the seismic force-resisting system must be checked.*

*Since Chapter 4 makes no requirement for in-plane stiffness of a floor diaphragm (similar to 1997 UBC section 1633.2.9 item 1, for example), this provision effectively exempts most plywood and diagonally sheathed diaphragms from any quantitative analysis.*

*“Wood diaphragms in structures that support floors or roofs above” is not meant to cover any diaphragms other than those already within the scope of section 403.2.*

*Rigid floor diaphragms are generally considered capable of rotating as rigid bodies without substantial distortion. They are therefore judged capable of transmitting forces if the seismic force-resisting system is not symmetric in*

## GUIDELINES FOR SEISMIC RETROFIT OF EXISTING BUILDINGS

*plan or even if the system has elements on only three sides. By restricting transmission of forces by rotation or cantilever, this provision is saying that wood diaphragms are inherently flexible. The existing seismic force-resisting system must therefore be supplemented as needed, assuming that the diaphragm can distribute forces based on tributary area. (As noted elsewhere in this commentary, recent CUREE testing has shown that the wood diaphragm in an open-front building can behave as essentially rigid, but that the resulting rotation can impose large drifts along the open-front wall line.)*

*The Building Code is cited for exceptions. If the Building Code is based on the 1997 UBC, those exceptions are given in section 2315.1. For codes based on the 2003 IBC, exceptions for rigid wood diaphragms only are in section 2305.2.5.*

*For buildings within the scope of Chapter 4, 1997 UBC section 2315.1 prohibits transmission of forces by rotation in the following cases:*

*In diaphragms with straight sheathing.*

*Where diaphragm cantilever exceeds the smaller of 25 ft or two thirds of the diaphragm width (with exceptions). (The width is the direction normal to the direction of the cantilever span.)*

*In concrete or masonry buildings. Thus, retrofit of a SWOF building with new concrete or masonry walls on three sides of open area would not be compliant.*

*“[R]otational effects shall be accounted for when unsymmetric wall stiffness increases shear demands” refers to torsional effects that increase the forces and drifts imposed on the seismic force-resisting system. As required by section 403.6, wood diaphragms must be modeled as rigid relative to the walls so that the effects of actual and accidental torsion can be conservatively estimated. In essence, the second paragraph of this provision requires a distribution of forces based on the more conservative of two analyses, one assuming a flexible diaphragm and one assuming a rigid diaphragm.*

*The “25 percent” value in the Exception is the same as that in the definition of Open Front Wall Lines. It is discussed in the commentary to that definition and illustrated in Figure C4-1. The requirement to account for rotational effects on shear walls should apply as well to existing or new elements of other seismic force resisting systems.*

**403.11 Shear walls.** Shear walls shall have sufficient strength and stiffness to resist the tributary seismic loads and shall conform to the special requirements of this section.

*Section 403.11 addresses only wood-framed shear walls. Concrete or masonry shear walls added for retrofit are to be evaluated against the demands of section 403.3 and detailed according to the Building Code for new construction.*

*Use of the term “tributary” in this provision does not mean that the design forces are to be derived from tributary floor areas, nor does it mean that rigid diaphragm analysis is not required.*

*The term “special” in this context indicates the “particular” requirements of this section; it is not related to either “special” seismic force-resisting systems or “special seismic load combinations.”*

**403.11.1 Gypsum or cement plaster products.** Gypsum or cement plaster products shall not be used to provide lateral resistance in the soft or weak story.

*“Gypsum” refers primarily to gypsum wallboard but also includes traditional gypsum plaster and gypsum lath (sometimes called buttonboard). “Cement plaster” refers to plaster with Portland cement, also known as stucco.*

*After the 1994 Northridge earthquake, some jurisdictions reduced by half the allowable shear values for gypsum wallboard and stucco and doubled the minimum wall panel lengths for Conventional Light-Frame Construction (Los Angeles, 1999). CUREE tests (2002) have shown that stucco can significantly increase the elastic stiffness and*

## GUIDELINES FOR SEISMIC RETROFIT OF EXISTING BUILDINGS

*strength of wood panel shear walls, but stucco alone is still considered too brittle a material for use in vulnerable elements such as cripple walls and SWOF story walls.*

*“[T]he soft or weak story” means whichever story or stories triggered the retrofit according to the scope conditions in section 401.2. The intention of the provision is that these nonconforming materials may not be counted as part of the seismic force-resisting system even when the SWOF condition has been mitigated by retrofit. Though only soft and weak stories are mentioned, this prohibition should apply to stories with open-front wall lines as well.*

### 403.11.2 Wood structural panels.

**403.11.2.1 Drift limit.** Wood structural panel shear walls shall meet the story drift limitation of Section 403.6. Conformance to the story drift limitation shall be determined by approved testing or calculation, or analogies drawing therefrom, and not by the use of an aspect ratio. Calculated deflection shall be determined according to UBC Standard 23-2, Section 23.223, “Calculation of Shear Wall Deflection,” and 25 percent shall be added to account for inelastic action and repetitive loading. Contribution to the shear wall deflection from the anchor or tie-down slippage shall also be included. The slippage contribution shall include the vertical elongation of the connector metal components, the vertical slippage of the connectors to framing members, localized crushing of wood due to bearing loads, and shrinkage of the wood elements because of changes in moisture content as a result of aging. The total vertical slippage shall be multiplied by the shear panel aspect ratio and added to the horizontal deflection. Individual shear panels shall be permitted to exceed the maximum aspect ratio, provided the story drift and shear capacities are not exceeded.

*The provision’s reference to UBC Standard 23-2 (which is also cited in 1997 UBC section 2315.1) may be understood to refer to corresponding requirements of the Building Code. The equation in Standard 23-2 can also be found in 2000 NEHRP Commentary section 12.4, the APA Design/Construction Guide for diaphragms and shear walls (APA 2001), and in 2000 IBC section 2305.3.2. (In the IBC, the final term of the equation is defined differently but represents the same thing as in the other versions of the equation.) Its derivation and history are described in APA Form No. TT-053 (APA 2000).*

*The equation defines the wall deflection as the sum of four contributions: flexural deformation of the wood, shear deformation of the wood, deformation due to nail slip, and rigid body rotation due to hold-down deformation or “slippage.” Nail slip data for use in the third term are given in APA (2001), Table A-2. Material data from outside sources is subject to the limitations of section 406.3.2. Additional information on wood shear wall design provisions is provided in APA (2001) and other documents available at [www.apawood.org](http://www.apawood.org).*

*The provision lists four effects that contribute to hold-down slippage, one of which is wood shrinkage. Slippage due to wood shrinkage should not be a concern in existing shear walls (unless the shrinkage occurred after an original hold-down was installed) or where wood structural panels are applied to existing framing.*

**403.11.2.2 Openings.** Shear walls are permitted to be designed for continuity around openings in accordance with Section 2315.1 of the UBC. Blocking and steel strapping shall be provided at corners of the openings to transfer forces from discontinuous boundary elements into adjoining panel elements. Alternatively, the perforated shear wall provisions of the IBC may be used.

*The provision refers to 1997 UBC section 2315.1 and to “the perforated shear wall provisions of the IBC.” These references may be understood to refer to corresponding requirements of the Building Code.*

*The intention of provisions such as 1997 UBC section 2315.1 is to assure performance that matches the characteristics assumed for analysis and design, principally that the shear wall acts as a unit, without substantial deformations or stress concentrations at openings. The specified UBC section refers to 1997 UBC Table 23-II-G, which has been modified slightly by errata published in September 1997, May 1998, and January 2001: the modified table no longer allows a height-to-width ratio greater than 2:1 for wood structural panel shear walls in Seismic Zones 0, 1, and 2.*

## **GUIDELINES FOR SEISMIC RETROFIT OF EXISTING BUILDINGS**

*Commentary, background, and design examples regarding perforated shear walls are available in the 2000 NEHRP Commentary, section 12.4.3.*

**403.11.2.3 Wood species of framing members.** Allowable shear values for wood structural panels shall consider the species of the framing members. When the allowable shear values are based on Douglas fir-larch framing members, and framing members are constructed of other species of lumber, the allowable shear values shall be multiplied by the following factors: 0.82 for species with specific gravities greater than or equal to 0.42 but less than 0.49, and 0.65 for species with specific gravities less than 0.42. Redwood shall use 0.65 and hem fir shall use 0.82, unless otherwise approved.

**403.11.3 Substitution for 3-inch (76 mm) nominal width framing members.** Two 2-inch (51 mm) nominal width framing members shall be permitted in lieu of any required 3-inch (76 mm) nominal width framing member when the existing and new framing members are of equal dimensions, when they are connected as required to transfer the in-plane shear between them, and when the sheathing fasteners are equally divided between them.

*Current design provisions for shear walls frequently require framing members of 3-inch nominal width. This provision recognizes that many existing buildings have only 2-inch nominal studs, and that it is more cost-effective to double the existing member than to replace it. The requirement for members of equal dimensions is intended to assure that the two pieces will be of roughly equivalent stiffness and will thus share loads roughly equally.*

*A new framing member of “wet” lumber should not be added to an existing dry member. When the wet piece shrinks, the non-uniform deformation could affect the integrity of the plywood nailing.*

*Connection for shear transfer should be based on calculation. Recent testing showed that studs nailed together can experience substantial slip under seismic loads (CUREE, 2002).*

*Where existing members are very dry and prone to splitting, a quality assurance plan should include confirmation that existing members are not being damaged by new work. Pre-drilling (with a bit  $\frac{3}{4}$  of the nail diameter) is one way to reduce splitting in dry members.*

*The provision is based on the common condition of existing framing with nominal dimensions. If the existing framing is unsurfaced lumber, then the stud width might already be a full two inches (as opposed to  $1\frac{1}{2}$  inches for a nominal 2x member). In that case, the existing member might be sufficient by itself.*

### **403.11.4 Hold-down connectors.**

**403.11.4.1 Expansion anchors in tension.** Expansion anchors that provide tension strength by friction resistance shall not be used to connect-hold down devices to existing concrete or masonry elements. Expansion anchors that provide tension strength by bearing (commonly referenced as “undercut” anchors) shall be permitted.

*Chemical (epoxy) and screw-type anchors should also be allowed for hold-downs. See the commentary under the definition of Expansion Anchor in section 402.*

*This provision prohibits friction-based expansion anchors for tension loads because of poor performance in the 1994 Northridge earthquake. Since then, approval criteria have been made more restrictive, and the design of some expansion anchors has been modified. Any anchor type with ICC-ES approval for cyclic tension loads should be acceptable in this application.*

**403.11.4.2 Required depth of embedment.** The required depth of embedment or edge distance for the anchor used in the hold-down connector shall be provided in the concrete or masonry below any plain

## **GUIDELINES FOR SEISMIC RETROFIT OF EXISTING BUILDINGS**

concrete slab unless satisfactory evidence is submitted to the building official that shows that the concrete slab and footings are of monolithic construction.

*“[M]onolithic construction” generally means concrete placed at the same time, with continuous reinforcing. A slab poured over the top of a previously placed footing will generally not be monolithic unless the top surface of the footing was roughened, bent reinforcing dowels connect the two pours, and there is no “visqueen” vapor barrier laid between the two pours. A slab with nominal reinforcing or wire mesh provided only for crack control should be considered “plain concrete.”*

*Another reason for embedment well into the footing is that curbs and short stem walls are frequently too narrow to provide adequate edge distance for the anchor and are therefore unable to develop its strength.*

**403.11.4.3 Required preload of bolted hold-down connectors.** Bolted hold-down connectors shall be preloaded to reduce slippage of the connector. Preloading shall consist of tightening the nut on the tension anchor after the placement but before the tightening of the shear bolts in the panel flange member. The tension anchor shall be tightened until the shear bolts are in firm contact with the edge of the hole nearest the direction of the tension anchor. Hold-down connectors with self-jigging bolt standoffs shall be installed in a manner to permit preloading.

*Improper installation of hold-downs has been responsible for poor performance in past earthquakes (SEAOC 1999, Appendix F; SEAOC 2003). Pre-loading is intended to ensure that the hold-down works as designed, with all of the bolts bearing simultaneously on the wood member. If existing hold-downs are exposed in the course of the work, they should be pre-loaded as well. Hold-down connectors with pointed self-jigging webs should have the point raised at least one inch above the sill plate to prevent the point from splitting the sill during tightening.*

### **SECTION 404 GENERAL REQUIREMENTS FOR PHASED CONSTRUCTION**

When the building contains three or more levels, the work specified in this chapter shall be permitted to be done in the following phases. Work shall start with Phase I unless otherwise approved by the building official. When the building does not contain the conditions shown in any phase, the sequence of retrofit work shall proceed to the next phase in numerical order.

**Phase 1 Work.** The first phase of the retrofit work shall include the ground floor portion of the wood structure that contains parking or other similar open floor space.

**Phase 2 Work.** The second phase of the retrofit work shall include walls of any level of wood construction with two or more levels above that are laterally braced with nonconforming structural materials.

**Phase 3 Work.** The third and final phase of the retrofit work shall include the remaining portions of the building up to, but not including, the top story as specified in Section 403.2.

*Phased construction is sometimes beneficial to owners. This provision is intended to prioritize work related to the most hazardous conditions and to assure that the building is not weakened by partial efforts or left in a more seismically vulnerable condition at any intermediate stage.*

*Phase 1 Work is intended to cover the lowest wood-framed story with a SWOF condition, regardless of whether it is the ground floor or is used for parking.*

# GUIDELINES FOR SEISMIC RETROFIT OF EXISTING BUILDINGS

## SECTION 405 PRESCRIPTIVE MEASURES FOR WEAK STORY

*This section is not limited to weak story conditions. Any structure that meets the qualifications is eligible for these prescriptive measures.*

*For buildings that qualify, section 405 is intended as an alternative to section 403. The requirements of sections 406, 407, and 408 still apply. The main purpose of this prescriptive alternative is to reduce the cost of engineered evaluation and design. It is expected that section 405 could be applied by a qualified contractor without the assistance of an engineer.*

*Section 405 is intended for a 2-story building with an uncomplicated footprint and a SWOF wall line on only one side. Figure C4-3 illustrates two such buildings in plan. The text of section 405 is written with tuckunder parking in mind. Parking, however, is not a prerequisite for this section; any SWOF condition and any ground floor use may be eligible.*

*The provisions of this section are not merely “proposed.” They are deemed acceptable for the buildings that qualify.*

**405.1 Scope.** The proposed prescriptive measures provided here are intended to reduce the earthquake vulnerability of the structure and to reduce the possibility of collapse or partial collapse of the building in the event of a moderate to major earthquake.

**405.1.1 Performance.** The improved earthquake performance of the structure due to the proposed prescriptive measures varies and is greatly controlled by all of the following: proximity to the fault line; soil type; weight of roof and floor above; quality of existing walls, posts and columns, and their connections to the floor diaphragm; and the quality of construction provided to comply with the prescriptive measures. The implementation of the proposed measures is not intended to improve the earthquake performance of the building above the first story.

*The performance objective throughout Chapter 4, including section 405, is Risk Reduction, as described in the commentary to section 401.1.*

*The provisions of section 405 are derived from judgement, not from testing, analysis, or performance statistics. No studies or tests have been performed to confirm that these prescriptive measures will result in the same performance with the same reliability as designs engineered to the provisions of section 403. Nevertheless, for the buildings that qualify, these prescriptive measures are expected to achieve the same Risk Reduction objective.*

**405.1.2 Limitation.** The proposed prescriptive measures rely on rotation of the second floor diaphragm to distribute the load between the side and rear wall enclosing the parking area. The owner shall provide access to ensure that the floor diaphragm is of wood structural panel or diagonal sheathing. In the absence of such a verification, a new wood structural panel diaphragm must be applied of minimum thickness of ¾ inch (19 mm) and with 10d common nails at 6 inches (152 mm) on center.

*See Figure C4-3 for illustration of “the side and rear wall.” In the bottom part of the figure, only the portion of the “side wall” between Lines A and B is considered to be “enclosing the parking area,” and only that portion should be counted toward the required wall length under these prescriptive measures. As noted in the commentary above, the building need not include parking.*

*A substantial floor diaphragm above the SWOF wall line is necessary for these provisions to provide reliable performance. A diaphragm of straight board sheathing is judged inadequate. Clearly, verification of the existing diaphragm is less costly and less disruptive than installation of a new plywood diaphragm.*

*The provision does not identify any detail requirements for the existing wood diaphragm. Instead, the provision appears to presume that the presence of a conforming material assures acceptable sheathing thickness, material*

## GUIDELINES FOR SEISMIC RETROFIT OF EXISTING BUILDINGS

*grade, condition, and nailing. No studies have been performed to determine what diaphragm strength is required for these prescriptive provisions to work reliably; in the absence of such studies, any criteria would be based on judgement alone. Still, if there is doubt as to the adequacy of the existing diaphragm, 1997 UBC sections 2315.3.1 and 2315.3.3 offer criteria for new construction that may be used as conservative benchmarks.*

*Where a new diaphragm is required, it may be applied over the existing sheathing or to the underside of the second floor joists. Application to the underside of the floor joists will often be less disruptive. Application on top of existing nonconforming sheathing presents the additional problems of aligning the panel edges with floor framing below and providing continuity across or under the sill plates of existing partitions. In either case, appropriate collector elements must also be provided.*

*The provision prescribes a new or additional diaphragm of  $\frac{3}{4}$  inch thickness with 10d nails at 6 inches. For new diaphragms with this nailing, 3 inch nominal framing members are required at panel edges per 1997 UBC Table 23-II-H.*

**405.1.3 Additional conditions.** To qualify for prescriptive measures, the following additional conditions need to be satisfied:

1. Diaphragm aspect ratio = 1.5 or less.
2. Minimum length of side shear walls = 20 feet (6096 mm) with less than 10 percent openings.
3. Minimum length of rear shear walls =  $\frac{3}{4}$  of rear wall length with individual walls not having more than 10 percent openings.

*The three listed conditions are in addition to those in section 403.1 Exception 2.*

*The ratios, wall lengths, and opening percentages in this provision are derived from judgement, not from testing, analysis, or performance statistics. The three conditions need not be satisfied by the existing building as long as they are satisfied by the retrofit. In other words, wall elements can be added and openings modified to meet the specified criteria. Whether new or existing, only walls that comply with section 405.2.3 should be counted for the purposes of satisfying these conditions.*

*The diaphragm aspect ratio provision is in error. With reference to Figure C4-3, the provision intends to require values of L/W less than or equal to 0.67, consistent with 2003 IBC section 2305.2.5.*

*L and W are the principal dimensions of the diaphragm bounded by the shear walls immediately adjacent to the SWOF wall line. The intention of the aspect ratio limit is to restrict the prescriptive provisions to buildings that are not prone to substantial torsion. Where the critical diaphragm is the entire second floor, as in the top part of Figure C4-3, the preferred condition has the SWOF wall line along the long side of the building so that the center of mass and the center of rigidity are close together and torsion is controlled. If the open wall line was along the short side, the three-sided structure would be subject to high torsion.*

*The bottom part of Figure C4-3 illustrates a potential shortcoming of this simple screening criterion. If L/W for this building were less than 0.67, it would not qualify for the prescriptive measures of section 405. Yet this building is arguably less vulnerable to torsion than the building in the top part of the figure. In the bottom part of the figure the critical condition is the demand on the wall along Line B due to torsional response.*

*For the building in the bottom part of Figure C4-3, the “side shear walls” include only the portions between Line A and Line B. The portion between Line B and Line C is not counted toward the required 20 feet. Reasonable designs that make use of wall lengths not immediately adjacent to the open area (that is, lengths between Lines B and C) are possible but should be subject to engineered design. For these prescriptive measures, it is appropriate to restrict certain design choices in order to ensure reliable outcomes in the absence of engineering calculations.*

*The “10 percent” limits on openings refer to the area of wall in the first story, not the length of wall. Only the portions of walls bounding the parking or open area should be considered.*

## GUIDELINES FOR SEISMIC RETROFIT OF EXISTING BUILDINGS

*In addition to the three listed limitations, the prescriptive measures of section 405 should also be limited to buildings with acceptable foundations so that the engineering requirements of section 403.2 regarding soil bearing pressure may be waived and so that the prescriptive anchor bolt and hold-down provisions may be implemented. In the absence of other criteria, minimum requirements for 2-story buildings from 1997 UBC Table 18-I-C (or corresponding values from other model codes) should be met: the side and rear walls considered by section 405 should have continuous concrete footings at least 6 inches thick and 12 inches wide, with bearing at least 12 inches below the undisturbed ground surface.*

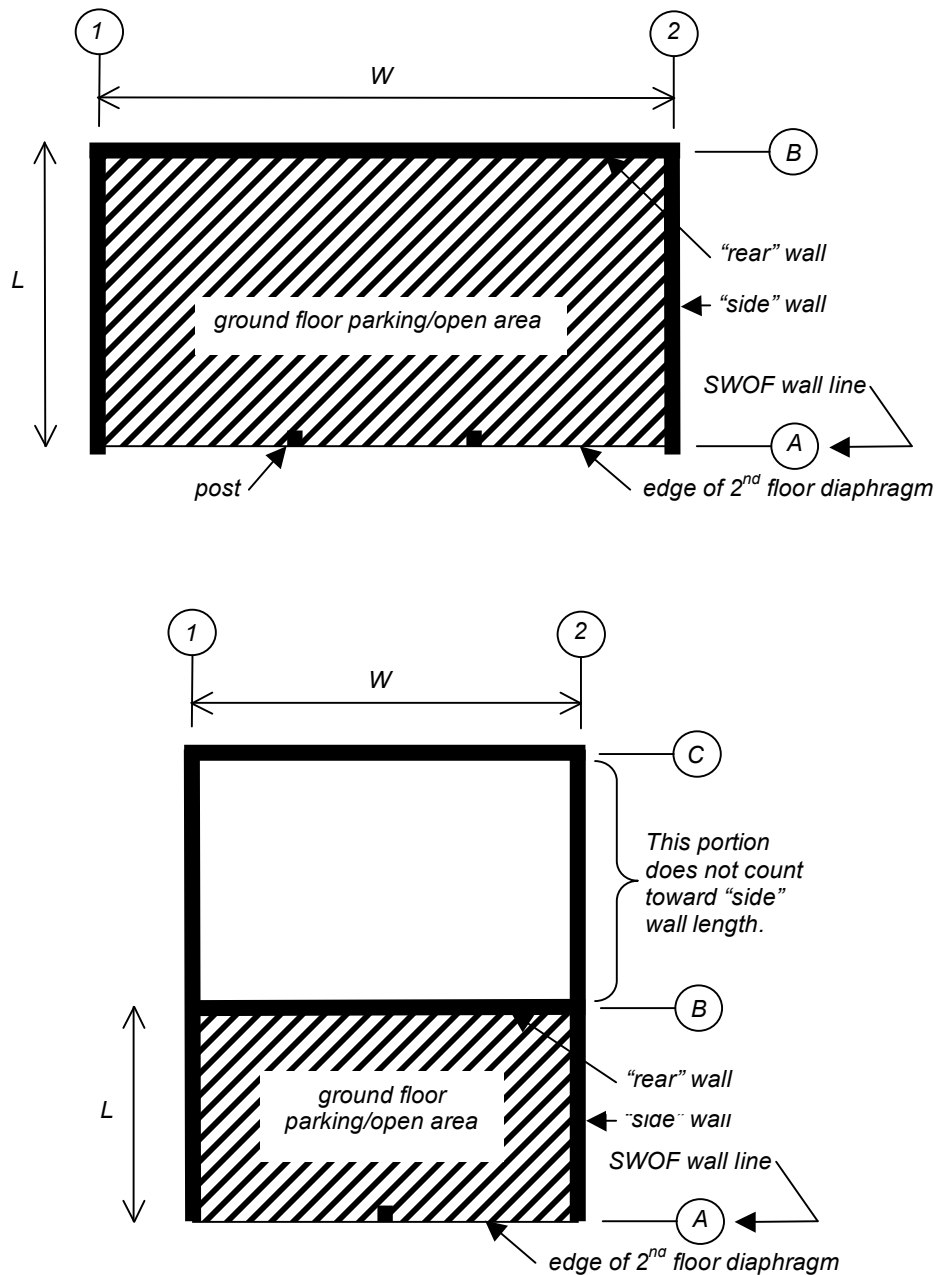

**Figure C4-3. Section 405 definitions.**

## **GUIDELINES FOR SEISMIC RETROFIT OF EXISTING BUILDINGS**

### **405.2 Minimum required retrofit.**

*For buildings that qualify, section 405 is intended as an alternative to section 403. The requirements of sections 406, 407, and 408 still apply.*

**405.2.1 Anchor bolt size and spacing.** The anchor bolt size and spacing shall be a minimum of  $\frac{3}{4}$  inch (19 mm) in diameter at 32 inches (813 mm) on center. Where existing bolts are inadequate, new steel plates bolted to the side of the foundation and nailed to the sill may be used, such as an approved connector.

*Anchor bolts as specified in this provision must be provided only along the length of the “side” and “rear” walls.*

*“[I]nadequate” refers principally to bolt size and spacing, but judgement should be applied where existing anchors indicate poor workmanship (oversized holes in sill plates, insufficient edge distance or embedment, etc.) or poor condition (corrosion, looseness, spalling, etc.).*

*Bolts added to comply with this provision need not be expansion anchors because they are intended principally to resist shear loads. Chemical anchors are preferred. See the commentary under Expansion Anchor in section 402.*

*The provision specifies  $\frac{3}{4}$  inch diameter bolts. Smaller bolts are sometimes necessary for proper edge distance in narrow sill plates or concrete curbs. These smaller bolt sizes may be used if 1. the Building Official approves, and 2. the designer demonstrates that the proposed bolt layout, which may combine new and existing bolts of different sizes, provides capacity equivalent to  $\frac{3}{4}$  inch bolts at 32 inches on center. If the new bolts are substantially stiffer than the existing bolts, then the existing bolts should not be counted toward the required capacity.*

*If new bolts are required, they must be installed through any new blocking at the sill plate required by section 405.2.3.*

*Embedment must be into the footing. See the commentary to section 403.11.4.2.*

*The provision allows approved steel plate connectors. These are commonly used for retrofit of cripple walls where cramped access prevents installation of new bolts vertically through the sill plate. This is less likely to be a concern in a SWOF building.*

**405.2.2 Connection to floor above.** Shear wall top plates shall be connected to blocking or rim joist at upper floor with a minimum of 18-gage galvanized steel angle clips  $4\frac{1}{2}$  inches (114 mm) long with 12-8d nails spaced no farther than 16 inches (406 mm) on center, or by equivalent shear transfer methods.

**405.2.3 Shear wall sheathing.** The shear wall sheathing shall be a minimum of  $\frac{15}{32}$  inch (11.9 mm) 5-Ply Structural I with 10d nails at 4 inches (102 mm) on center at edges and 12 inches (305 mm) on center at field; blocked all edges with 3 by 4 or larger. Where existing sill plates are less than 3-by thick, place flat 2-by on top of sill between studs, with flat 18-gage galvanized steel clips  $4\frac{1}{2}$  inches (114 mm) long with 12-8d nails or 3/8-inch-diameter (9.5 mm) lags through blocking for shear transfer to sill plate. Stagger nailing from wall sheathing between existing sill and new blocking. Anchor new blocking to foundation as specified above.

*The requirements for  $\frac{1}{2}$  inch 5-ply sheathing and 3x framing and blocking are consistent with changes made to building codes after the 1994 Northridge earthquake. For additional discussion of their background, see Harder (1994) and SEAOC (1999), Appendix F.*

*The provision makes no allowance for existing  $\frac{3}{8}$  inch sheathing. For these prescriptive measures, the specified sheathing is required without exception. If the existing sheathing is  $\frac{1}{2}$  inch, nail size and spacing must be verified; the nailing must be sufficient to develop the capacity equivalent to that required by the provision. If the existing sheathing or nailing does not meet the prescriptive requirements, the engineered approach of section 403 may be used to take advantage of their strength contribution.*

## **GUIDELINES FOR SEISMIC RETROFIT OF EXISTING BUILDINGS**

*If the required 1/2 inch sheathing is applied to studs already sheathed with lesser material, care should be taken not to split the existing wall studs with new nailing. Doubled studs, pre-drilled holes, or lag screws may be beneficial in this regard.*

*Where existing framing is less than 3x nominal, studs may be doubled per section 403.11.3.*

*Sheathing applied to the inside face of existing studs should be provided with ventilation and inspection holes. GSREB Chapter 3 section 304.4.3 provides some guidance.*

**405.2.4 Shear wall hold-downs.** Shear walls shall be provided with hold-down anchors at each end. Two hold-down anchors are required at intersecting corners. Hold-downs shall be approved connectors with a minimum 5/8-inch-diameter (15.9 mm) threaded rod or other approved anchor with a minimum allowable load of 4000 pounds (17.8 kN). Anchor embedment in concrete shall not be less than 5 inches (127 mm). Tie-rod systems shall not be less than 5/8 inch (15.9 mm) in diameter unless using high strength cable. Threaded rod or high strength cable elongation shall not exceed 5/8 inch (15.9 mm) using design forces.

*While the design provisions of section 403 are generally waived, applicable portions of the hold-down provisions of section 403.11.4 should be applied in addition to those given here.*

*The hold-down capacity might be limited by available concrete strength or edge distance. It is acceptable to use two 2000 lb hold-downs, one on each side of the post, in lieu of a single 4000 lb hold-down.*

*The hold-down capacity might also be limited by the inability of a small footing and its overburden to resist uplift in the first place. For purposes of section 405, the presumption is that the minimum footing dimensions recommended in the commentary to section 405.1.3 are acceptable for these prescriptive hold-down requirements.*

*The minimum embedment into the footing should be the larger of 5 inches or the manufacturer's recommendation. See the commentary to section 403.11.4.2.*

*Posts to which hold-downs are connected should be sufficient to prevent failures due to hold-down eccentricity. Posts built-up from multiple 2x or 3x members are acceptable if adequately connected (see the commentary to section 403.11.3) but 4x posts are preferred.*

*For the prescriptive measures of section 405, there are no calculated "design forces." Thus, the final sentence of this provision may be satisfied by assuring that the elongation does not exceed 5/8 inch at the allowable load of 4000 lb. This interpretation applies for hold-downs in the typical location just above the sill plate.*

### **SECTION 406 MATERIALS OF CONSTRUCTION**

**406.1 New materials.** All materials approved by this code, including their appropriate allowable stresses and minimum aspect ratios, shall be permitted to meet the requirements of this chapter.

*"[T]his code" may be understood to mean the Building Code.*

**406.2 Allowable foundation and lateral pressures.** Allowable foundation and lateral pressures shall be permitted to use the values from UBC Table 18-I-A. The coefficient of variation of subgrade reaction shall be established by an approved geotechnical engineering report or other approved methods when used in the deflection calculations of embedded vertical elements as required in Section 403.6.

*The provision's reference to UBC Table 18-I-A may be understood to refer to the corresponding requirements of the Building Code.*

## **GUIDELINES FOR SEISMIC RETROFIT OF EXISTING BUILDINGS**

*See the commentary to section 403.2 for additional discussion of soil bearing pressures and the commentary to section 403.6 for additional discussion of the coefficient of subgrade reaction.*

**406.3 Existing materials.** All existing materials shall be in sound condition and constructed in conformance to this code before they can be used to resist the lateral loads prescribed in this chapter. The verification of existing material conditions and their conformance to these requirements shall be made by physical observation reports, material testing or record drawings as determined by the structural designer and as approved by the building official.

*“[T]his code” may be understood to mean the Building Code.*

*The provision offers no standards or criteria for condition assessment. In general, the intention of the provision is to rule out significant construction defects, deferred maintenance, and unrepaired damage to structural members on the seismic load path. Based on the last sentence, the expectation of the provision is that appropriate condition assessment might require only reference to existing documents but might in some cases require destructive investigation or testing. Absent specific provisions, the appropriate inspection scope, personnel, and acceptance criteria are left to the designer of record. Where the prescriptive measures of section 405 are used, the designer of record will likely be the contractor.*

*Some guidance on condition assessment can be found in FEMA 356. GSREB Chapter 3 section 304.1.2 offers provisions that might be useful for assessment of wood members with potential fungus or insect infestation.*

*“[C]onstructed in conformance” in the context of this provision should be understood to refer to the general quality of construction, not to the adequacy of design or detailing. The intention of the provision is to ensure that load path elements will not fail prematurely due to errors or omissions in the original construction, such as “shiner” nails, misplaced anchor bolts or hold-downs, etc. Defects common to typical wood-framed buildings are discussed in Seismology (1999, Appendix F), and Harder (1994). In addition, clearly archaic construction, such as an unreinforced brick foundation, is not considered to be “constructed in conformance.”*

**406.3.1 Horizontal wood diaphragms.** Existing horizontal wood diaphragms that require analysis under Section 403.10 shall be permitted to use Table 4-E for their allowable values.

*The design forces prescribed in section 403 are at a strength level. When using the values in Table 4-E, the diaphragm design forces should be reduced by 1.4.*

### **406.3.2 Wood-structural-panel shear walls.**

**406.3.2.1 Allowable nail slip values.** When the required drift calculations of Section 403.11.2.1 rely on the lower slip values for common nails or surfaced dry lumber, their use in construction shall be verified by exposure. The use of box nails and unseasoned lumber may be assumed without exposure. The design value of the box nails shall be assumed to be similar to that of common nails having the same diameter. Verification of surfaced dry lumber shall be by identification conforming to UBC Section 2340.1.

*“2340.1” is a typographical error. The last sentence of the provision should read “2304.1.” The reference to the 1997 UBC may be understood to refer to the corresponding requirements of the Building Code.*

*Existing members may be assumed to be dry. The required verification need only apply to new lumber.*

**406.3.2.2 Plywood panel construction.** When verification of the existing plywood materials is by use of record drawings alone, the panel construction for plywood shall be assumed to be of three plies. The plywood modulus “G” shall be assumed equal to 50,000 pounds per square inch (345 MPa).

*Visual verification usually requires no more than a small core sample.*

## **GUIDELINES FOR SEISMIC RETROFIT OF EXISTING BUILDINGS**

**406.3.3 Existing wood framing.** Wood framing is permitted to use the design stresses specified in the building code under which the building was constructed or other stress criteria approved by the building official.

**406.3.4 Structural steel.** All existing structural steel shall be permitted to use the allowable stresses for Grade A36. Existing pipe or tube columns shall be assumed to be of minimum wall thickness unless verified by testing or exposure.

**406.3.5 Strength of concrete.** All existing concrete footings shall be permitted to use the allowable stresses for plain concrete with a compressive strength of 2,000 pounds per square inch (13.8 MPa). The strength of the existing concrete with a recorded compressive strength greater than 2,000 pounds per square inch (13.8 MPa) shall be verified by testing, record drawings or department drawings.

*With reference to section 406.3, existing unreinforced brick foundations are not considered to be “constructed in conformance” with applicable codes and therefore may not be used to resist earthquake effects in the retrofitted structure.*

**406.3.6 Existing sill plate anchorage.** Existing cast-in-place anchor bolts shall be permitted to use the allowable service loads for bolts with proper embedment when used for shear resistance to lateral loads.

### **SECTION 407 REQUIRED INFORMATION ON THE PLANS**

**407.1 General.** The plans shall show all necessary dimensions and materials for plan review and construction and shall accurately reflect the results of the engineering investigation and design. Details specific to the actual condition found shall be shown on the drawings to assure installation of all elements required for construction of the necessary complete load path. The plans shall contain a note that states that this retrofit was designed in compliance with the criteria of Chapter 4 of the *Guidelines for the Seismic Retrofit of Existing Buildings*.

*The requirements of this section are in addition to any other documentation required by the Building Code or the Building Official.*

*Documentation requirements regarding calculated member capacities, design forces, or results of engineering analysis may be waived when the prescriptive measures of section 405 are used.*

*The intent of this provision, particularly its second sentence, is to assure that the designer has accounted for any existing conditions that might compromise the seismic load path or interfere with the intended details. An investigation should verify representative load path details. Specific conditions might require additional field investigation and detailing during the construction phase.*

*The note required by the last sentence of the provision should specify the 2000 Edition of the GSREB. The Building Code should be noted as well.*

**407.2 Existing construction.** The plans shall show existing diaphragm and shear wall sheathing and framing materials; fastener type and spacing; diaphragm and shear wall connections; continuity ties; and collector elements. The plans shall also show the portion of the existing materials that needs verification during construction.

*Details of existing construction need only be shown for the areas within the scope of the retrofit as indicated by section 403.2.*

*Chapter 4 provisions that address verification include section 406.3 (general condition assessment), 405.1.2 (diaphragm type), 405.2.1 (anchor bolts), 406.3.2.1 (wood shear wall construction), 406.3.4 (steel tube thickness), and 406.3.5 (concrete strength).*

## **GUIDELINES FOR SEISMIC RETROFIT OF EXISTING BUILDINGS**

### **407.3 New construction.**

**407.3.1 Foundation plan elements.** The foundation plan shall include the size, type, location and spacing of all anchor bolts with the required depth of embedment, edge and end distance; the location and size of all columns for braced or moment frames; referenced details for the connection of braced or moment-resisting frames to their footing; and referenced sections for any grade beams and footings.

*Hold-down locations should be shown on the foundation plan as well.*

**407.3.2 Framing plan elements.** The framing plan shall include the width, location and material of shear walls; the width, location and material of frames; references on details for the column-to-beam connectors, beam-to-wall connections, and shear transfers at floor and roof diaphragms; and the required nailing and length for wall top plate splices.

**407.3.3 Shear wall schedule, notes and details.** Shear walls shall have a referenced schedule on the plans that includes the correct shear wall capacity in pounds per foot (N/m); the required fastener type, length, gauge and head size; and a complete specification for the sheathing material and its thickness. The schedule shall also show the required location of 3-inch (76 mm) nominal or two 2-inch (51 mm) nominal edge members; the spacing of shear transfer elements such as framing anchors or added sill plate nails; the required hold-down with its bolt, screw or nail sizes; and the dimensions, lumber grade and species of the attached framing member.

Notes shall show required edge distance for fasteners on structural wood panels and framing members; required flush nailing at the plywood surface; limits of mechanical penetrations; and the sill plate material assumed in the design. The limits of mechanical penetrations shall also be detailed showing the maximum notching and drilled hole sizes.

*See the commentary to section 407.1 regarding documentation of member capacities on plans.*

*The intention of this provision is to document new and modified elements. The extensive list indicates the importance of quality control for shear walls.*

*“[C]omplete specification” means enough information to assure selection of the correct product by the builder and to allow inspection by the authority having jurisdiction. Reference to a material standard and a panel grade designation is generally sufficient (for example, “1997 UBC Standard 23-2, Structural I,” or “United States Voluntary Product Standard PS 1-95, Structural I”).*

**407.3.4 General notes.** General notes shall show the requirements for material testing, special inspection, structural observation and the proper installation of newly added materials.

*In accordance with section 403.1, the testing and inspection requirements are the same as those for new construction. For example, see 1997 UBC Chapter 17.*

## **SECTION 408 QUALITY CONTROL**

**408.1 Structural observation.** All structures regulated by this chapter require structural observation. The owner shall employ the engineer or architect responsible for the structural design, or another engineer or architect designated by the engineer or architect responsible for the structural design, to perform structural observation as defined in the UBC.

## **GUIDELINES FOR SEISMIC RETROFIT OF EXISTING BUILDINGS**

*In accordance with section 403.1, the structural observation requirements are generally the same as those for new construction. For example, see 1997 UBC Chapter 17, section 1702. However, retrofit projects routinely involve unanticipated conditions. The designer and builder should make allowances for such conditions when developing a project schedule and quality control plan.*

# GUIDELINES FOR SEISMIC RETROFIT OF EXISTING BUILDINGS

## BASIC STRUCTURAL CHECKLIST

*See the commentary to section 403.1.1.*

**TABLE 4-A—BUILDING SYSTEM**

C	NC	N/A	LOAD PATH: The structure shall contain one complete load path for seismic force effects from any horizontal direction that serves to transfer the inertial forces from the mass to the foundation.
C	NC	N/A	WEAK STORY: The strength of the lateral-force-resisting system in any story shall not be less than 80 percent of the strength in an adjacent story above or below.
C	NC	N/A	SOFT STORY: The stiffness of the lateral-force-resisting system in any story shall not be less than 70 percent of the stiffness in an adjacent story above or below, or less than 80 percent of the average stiffness of the three stories above or below.
C	NC	N/A	VERTICAL DISCONTINUITIES: All vertical elements in the lateral-force-resisting systems shall be continuous to the foundation.
C	NC	N/A	DETERIORATION OF WOOD: There shall be no signs of decay, shrinkage, splitting, fire damage or sagging in any of the wood members, and none of the metal accessories shall be deteriorated, broken or loose.
C	NC	N/A	WALL ANCHORAGE: Exterior concrete or masonry walls shall be anchored for out-of-plane forces at each diaphragm level with steel anchors or straps that are developed into the diaphragm. Straps shall be minimum 7 gage.

*The soft story definition given here differs slightly from the one in section 402. The definition in section 402 should be used for checking scope requirements of section 401.2.*

**TABLE 4-B—LATERAL-FORCE-RESISTING SYSTEM<sup>1</sup>**

C	NC	N/A	REDUNDANCY: The number of lines of shear walls in each principal direction shall be greater than or equal to two.
C	NC	N/A	SHEAR STRESS CHECK: The shear stress in the shear walls shall be less than the following values: 5-Ply structural panel sheathing: 400 plf (5.8 kN/m) 3-Ply structural panel and diagonal sheathing: 200 plf (2.9 kN/m) Straight sheathing: 80 plf (1.2 kN/m)
C	NC	N/A	STUCCO (EXTERIOR PLASTER) SHEAR WALLS: Multistory buildings shall not rely on exterior stucco walls as the primary lateral-force-resisting system.
C	NC	N/A	GYPSUM WALLBOARD OR PLASTER SHEAR WALLS: Interior plaster or gypsum wallboard shall not be used as shear walls on buildings over one story in height.
C	NC	N/A	NARROW WOOD SHEAR WALLS: Narrow wood shear walls with an aspect ratio greater than 2:1 for life safety shall not be used to resist lateral forces developed in the building.
C	NC	N/A	WALLS CONNECTED THROUGH FLOORS: Shear walls shall have interconnection between stories to transfer overturning and shear forces through the floor.
C	NC	N/A	HILLSIDE SITE: For a sloping site greater than 1 vertical in 3 horizontal and with greater than one-half story above the base, the base shear in the downhill direction, including forces from the base-level diaphragm, shall be resisted through primary anchors from diaphragm struts or collectors provided in the base-level framing to the foundation.
C	NC	N/A	CRIPPLE WALLS: All cripple walls below first-floor-level shear walls shall be braced to the foundation with shear elements.
C	NC	N/A	OPENINGS: Walls with garage doors or other large openings shall be braced with plywood shear walls or shall be supported by adjacent construction through substantial positive ties.
C	NC	N/A	HOLD-DOWN ANCHORS: All walls shall have properly constructed hold-down anchors.

1. The Basic Structural Checklist shall be completed prior to completing this Supplemental Structural Checklist.

*The limiting values given under Shear Stress Check are appropriate for allowable stress design. Design forces based on a strength design approach (for example, the loads specified in section 403.3) should be reduced to allowable stress levels before comparison with the limiting values provided.*

*The Shear Stress Check item includes a limiting value for straight sheathing. While this is listed for evaluation purposes, straight sheathing is not allowed when the prescriptive measures of section 405 are used. See section 405.1.2.*

## GUIDELINES FOR SEISMIC RETROFIT OF EXISTING BUILDINGS

**TABLE 4-C—CONNECTIONS<sup>1</sup>**

C	NC	N/A	WOOD POSTS: There shall be a positive connection of wood posts to the foundation.
C	NC	N/A	WOOD SILLS: All wood sills shall be bolted to the foundation.
C	NC	N/A	GIRDER/COLUMN CONNECTION: There shall be a positive connection between the girder and the column support.
C	NC	N/A	WOOD SILL BOLTS: Sill bolts shall be spaced at 6 feet or less, with proper edge distance provided for wood and concrete.

For SI: 1 foot = 304.8 mm.

1. The Basic Structural Checklist shall be completed prior to completing this Supplemental Structural Checklist.

**TABLE 4-D—DIAPHRAGMS<sup>1</sup>**

C	NC	N/A	DIAPHRAGM CONTINUITY: The diaphragms shall not be composed of split-level floors. In wood buildings, the diaphragms shall not have expansion joints.
C	NC	N/A	ROOF CHORD CONTINUITY: All chord elements shall be continuous, regardless of changes in roof elevation.
C	NC	N/A	STRAIGHT SHEATHING: All straight-sheathed diaphragms shall have aspect ratios less than 2:1.
C	NC	N/A	SPANS: All wood diaphragms with spans greater than 24 feet shall consist of wood structural panels or diagonal sheathing. Wood commercial and industrial buildings may have rod-braced systems.
C	NC	N/A	UNBLOCKED DIAPHRAGMS: All unblocked wood-structural-panel diaphragms shall have horizontal spans less than 40 feet and shall have aspect ratios less than or equal to 4:1.

For SI: 1 foot = 304.8 mm.

1. The Basic Structural Checklist shall be completed prior to completing this Supplemental Structural Checklist.

**TABLE 4-E—ALLOWABLE VALUES FOR EXISTING MATERIALS**

EXISTING MATERIALS OR CONFIGURATIONS OF MATERIALS <sup>1</sup>		ALLOWABLE VALUES x 14.594 for N/m
1.	Horizontal diaphragms <sup>2</sup>	
	1.1 Roofs with straight sheathing and roofing applied directly to the sheathing	100 lbs. per ft. for seismic shear
	1.2 Roofs with diagonal sheathing and roofing applied directly to the sheathing	250 lbs. per ft. for seismic shear
	1.3 Floors with straight tongue-and-groove sheathing	100 lbs. per ft. for seismic shear
	1.4 Floors with straight sheathing and finished wood flooring with board edges offset or perpendicular	500 lbs. per ft. for seismic shear
	1.5 Floors with diagonal sheathing and finished wood flooring	600 lbs. per ft. for seismic shear
2.	Crosswalls <sup>2,3</sup>	Per side:
	2.1 Plaster on wood or metal lath	200 lbs. per ft. for seismic shear
	2.2 Plaster on gypsum lath	175 lbs. per ft. for seismic shear
	2.3 Gypsum wallboard, unblocked edges	75 lbs. per ft. for seismic shear
	2.4 Gypsum wallboard, blocked edges	125 lbs. per ft. for seismic shear
3.	Existing footings, wood framing, structural steel and reinforced steel	
	3.1 Plain concrete footings	$f'_c = 1,500$ psi (10.3 MPa) unless otherwise shown by tests <sup>4</sup>
	3.2 Douglas fir wood	Allowable stress same as D.F. No. 1 <sup>4</sup>
	3.3 Reinforcing steel	$f_s = 18,000$ psi (124 MPa) maximum <sup>4</sup>
	3.4 Structural steel	$f_s = 20,000$ psi (138 MPa) maximum <sup>4</sup>

For SI: 1 foot = 304.8 mm.

1. Material must be sound and in good condition.
2. A one-third increase in allowable stress is not allowed.
3. Shear values of these materials may be combined, except the total combined value shall not exceed 300 pounds per foot.
4. Stresses given may be increased for combination of loads as specified in the Building Code.

*The values in Table 4-E are allowable values appropriate for allowable stress design. Design forces based on a strength design approach (for example, the loads specified in section 403.3) should be reduced to allowable stress levels before comparison with the limiting values provided.*

# GUIDELINES FOR SEISMIC RETROFIT OF EXISTING BUILDINGS

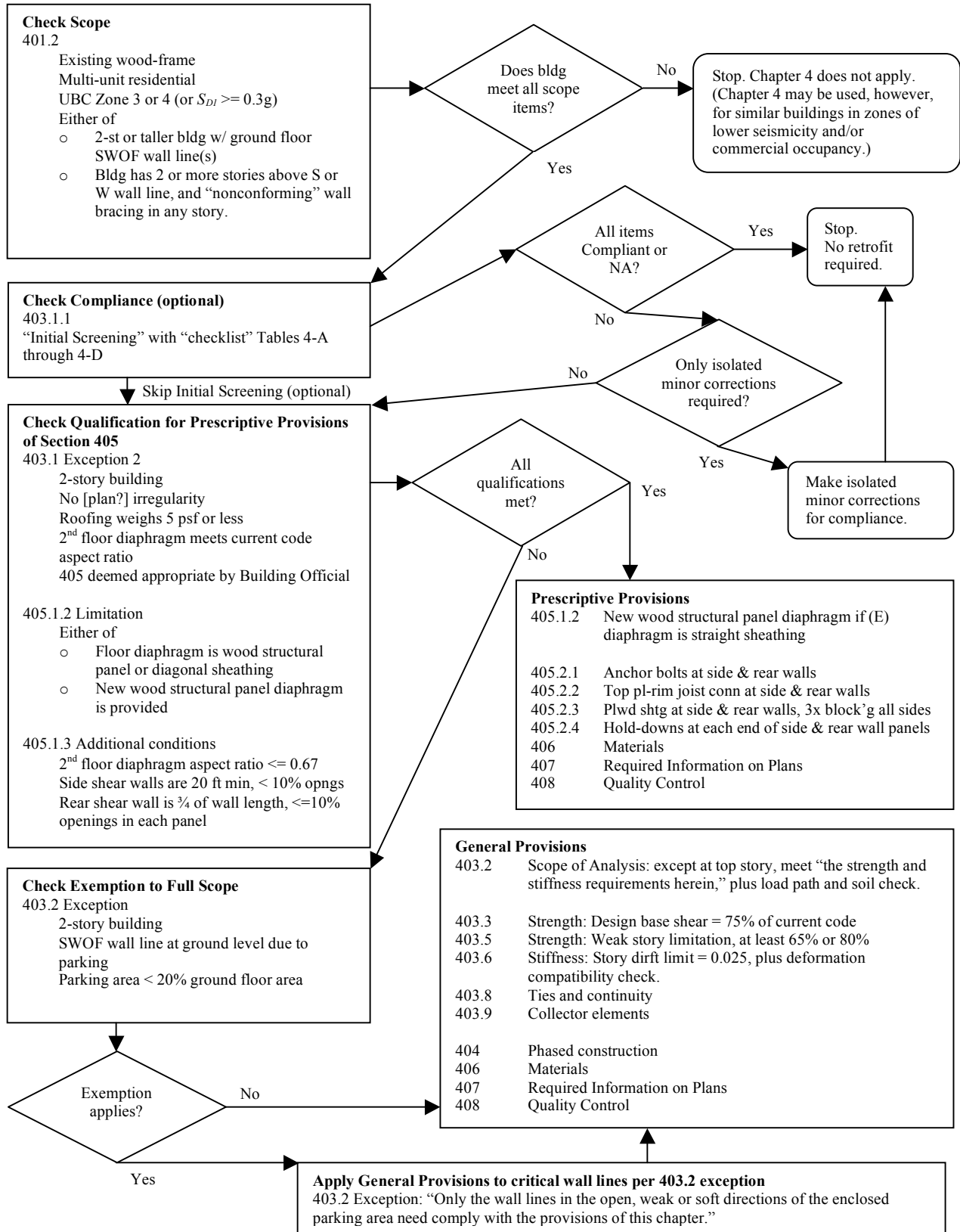

**Figure C4-4. Flowchart of Chapter 4 provisions.**

# **GUIDELINES FOR SEISMIC RETROFIT OF EXISTING BUILDINGS**

## **COMMENTARY REFERENCES**

- APA (2000). "Wood structural panel shear wall deflection formula" (Form No. TT-053). APA, Technical Services Division, August. (Available from [www.apawood.org](http://www.apawood.org).)
- APA (2001). Diaphragms and shear walls: Design/construction guide (Form No. L350G). APA, September. (Available from [www.apawood.org](http://www.apawood.org).)
- ASCE (1998). Handbook for the Seismic Evaluation of Buildings—A Prestandard (FEMA 310). Federal Emergency Management Agency, Washington, D.C., January.
- CUREE (2002). Recommendations for Earthquake Resistance in the Design and Construction of Woodframe Buildings, Part I – Recommendations and Part II – Topical Discussions (Final Review Draft), Consortium of Universities for Research in Earthquake Engineering, Richmond, CA, November 15.
- Fremont, City of. Ordinance No. 2363.
- Hamburger, R. (1994). "Lessons learned in the Northridge earthquake on wood frame buildings," in Seminar Papers: Northridge Earthquake, Lessons Learned, SEAONC 1994 Spring Seminar, Structural Engineers Association of Northern California, San Francisco.
- Harder, Robert (1994). "City of Los Angeles Department of Building and Safety and Structural Engineers Association of Southern California Joint Task Force: Wood Frame Construction Code Recommendations," in Proceedings: 63<sup>rd</sup> Annual Convention (1994 SEAOC Convention), Structural Engineers Association of California.
- Harris, S.K., Scawthorn, C., and Egan, J. (1990). "Damage in the Marina district of San Francisco in the October 17, 1989 Loma Prieta earthquake," in Proceedings of the 8<sup>th</sup> Japan Earthquake Engineering Symposium, Tokyo.
- Holmes, W. and Somers, P., editors (1996). Northridge Earthquake of January 17, 1994 Reconnaissance Report, Volume 2. Earthquake Spectra, supplement C to volume 11, January.
- ICBO (1997). 1997 Uniform Building Code, International Conference of Building Officials, Whittier, CA.
- ICC (2002). 2003 International Building Code, International Code Council, Country Club Hills, IL.
- LADBS (1999). "Multistory wood frame buildings with non-conforming structural materials and tuck-under parking features: Summary of wood light-frame building subcommittee (Draft version 5.7.99)," LADBS/SCEC/SEAOSC Ground Motion Joint Task Force Committee, March.
- Los Angeles, City of (1999). 1998 Los Angeles Building Code, Chapter 93, International Conference of Building Officials, Whittier, CA.
- Mendes, S. (1995). "Lessons learned from four earthquake damaged multi-story Type V structures," in Proceedings: 64<sup>th</sup> Annual Convention, 1995 SEAOC Convention, Indian Wells, CA.
- Rutherford and Chekene, (2000). Seismic Rehabilitation of Three Model Buildings with Tuckunder Parking: Engineering Assumptions and Cost Information, San Jose Department of Housing and Office of Emergency Services, May.
- Seismology Committee, SEAOC (1999). Recommended Lateral Force Requirements and Commentary, Seventh Edition, Structural Engineers Association of California, Sacramento.
- Stewart, J., Bray, J., McMahon, D., and Kropp, A. (1995). "Seismic performance of hillside fills," in Geotechnical Special Publication No. 52, American Society of Civil Engineers.

## **GUIDELINES FOR SEISMIC RETROFIT OF EXISTING BUILDINGS**

*Vukazich, S. (1998). The Apartment Owner's Guide to Earthquake Safety, City of San Jose, Residential Seismic Safety Program, August.*